

# The AI Growth Engine for Service Businesses

Scale revenue,  
not headcount.

**AiBuilder.services**

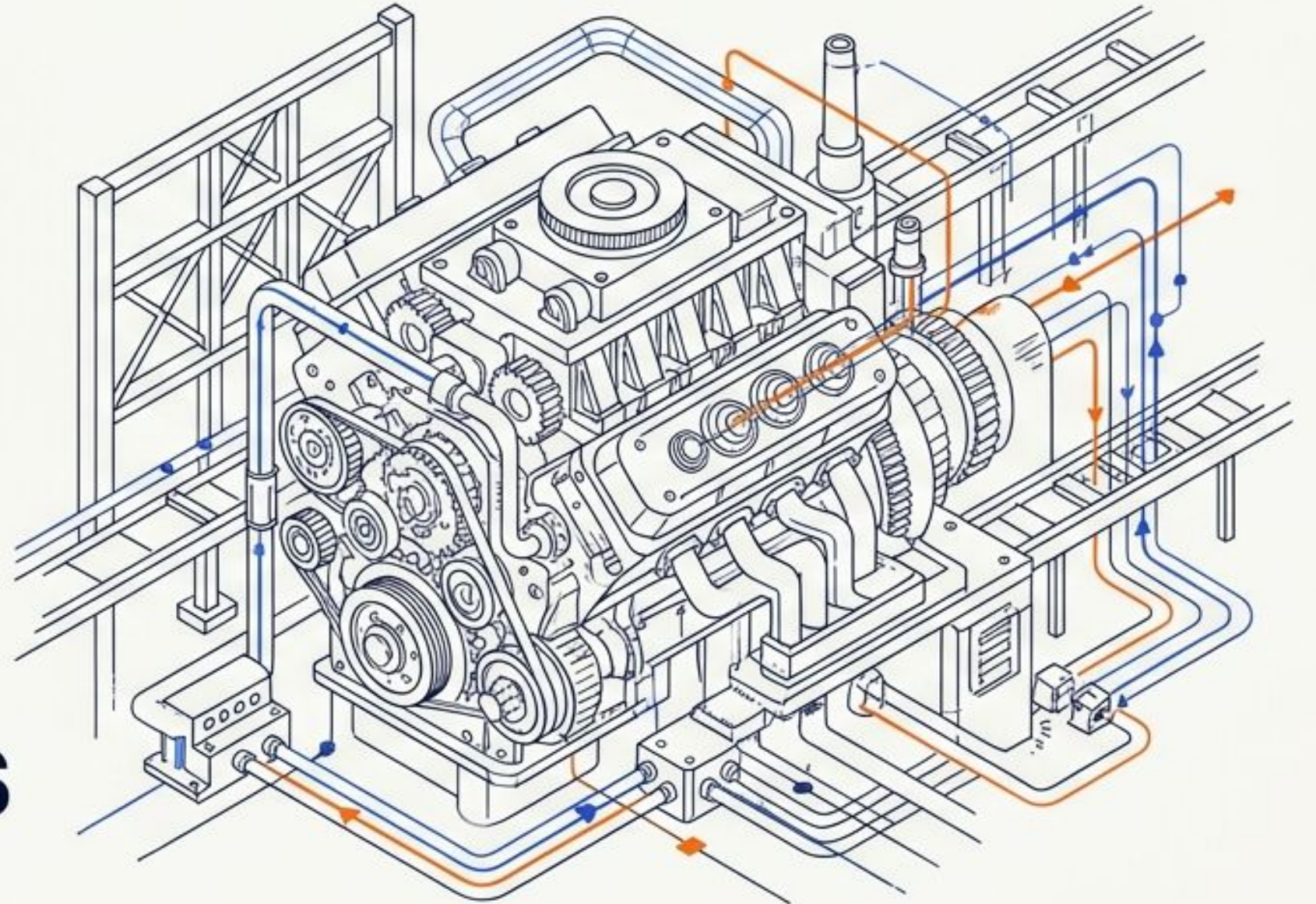

# The AI RevOps Blueprint: From Silos to Predictive Growth

The Capabilities: Activating AI Across the Customer Journey

## Achieve >95% Forecast Accuracy

AI analyzes deal engagement and conversation sentiment to predict revenue and flag risks.

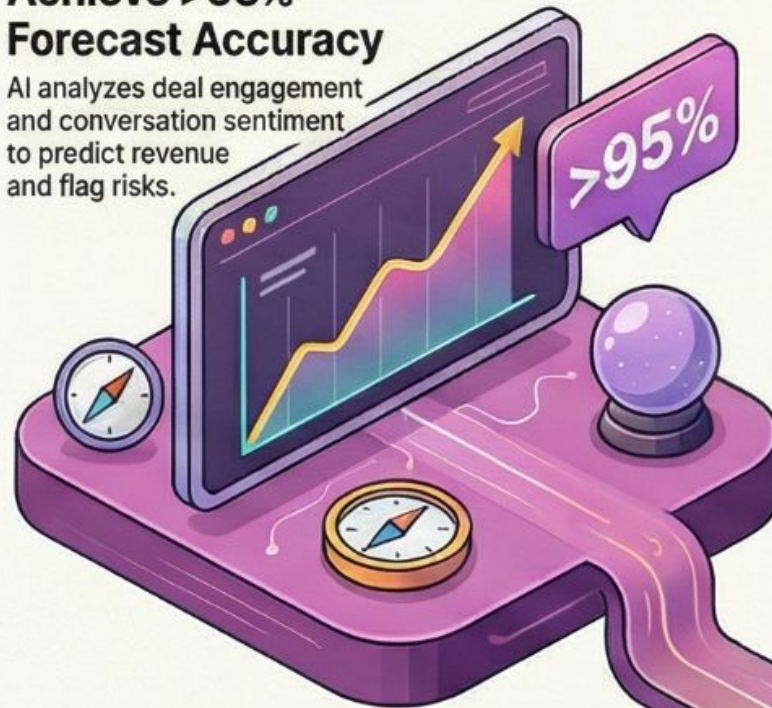

## Automate Lead Scoring & Routing

AI instantly identifies and routes the highest-potential leads to the right sales reps.



## Reduce Churn by 5% to Boost Profits by up to 95%

AI proactively identifies at-risk customers, triggering retention playbooks before they leave.



The Foundation: Building an AI-Ready Revenue Engine

## Establish a Unified Data Foundation

A Single Source of Truth (SSoT) is non-negotiable for training accurate AI models.



## Enforce Rigorous Data Governance

High-quality, governed data is the fuel for reliable and trustworthy AI predictions.



## Integrate Your Technology Stack

Unified platforms eliminate data silos and automate workflows across the customer journey.



# Turn Customer Communication Into a Revenue Engine

For service businesses, communication is everything. Consolidate scattered tools and manual follow-ups into a single AI layer. Ensure every conversation is a catalyst for satisfaction, conversion, and growth without adding overhead.

## Traditional Growth

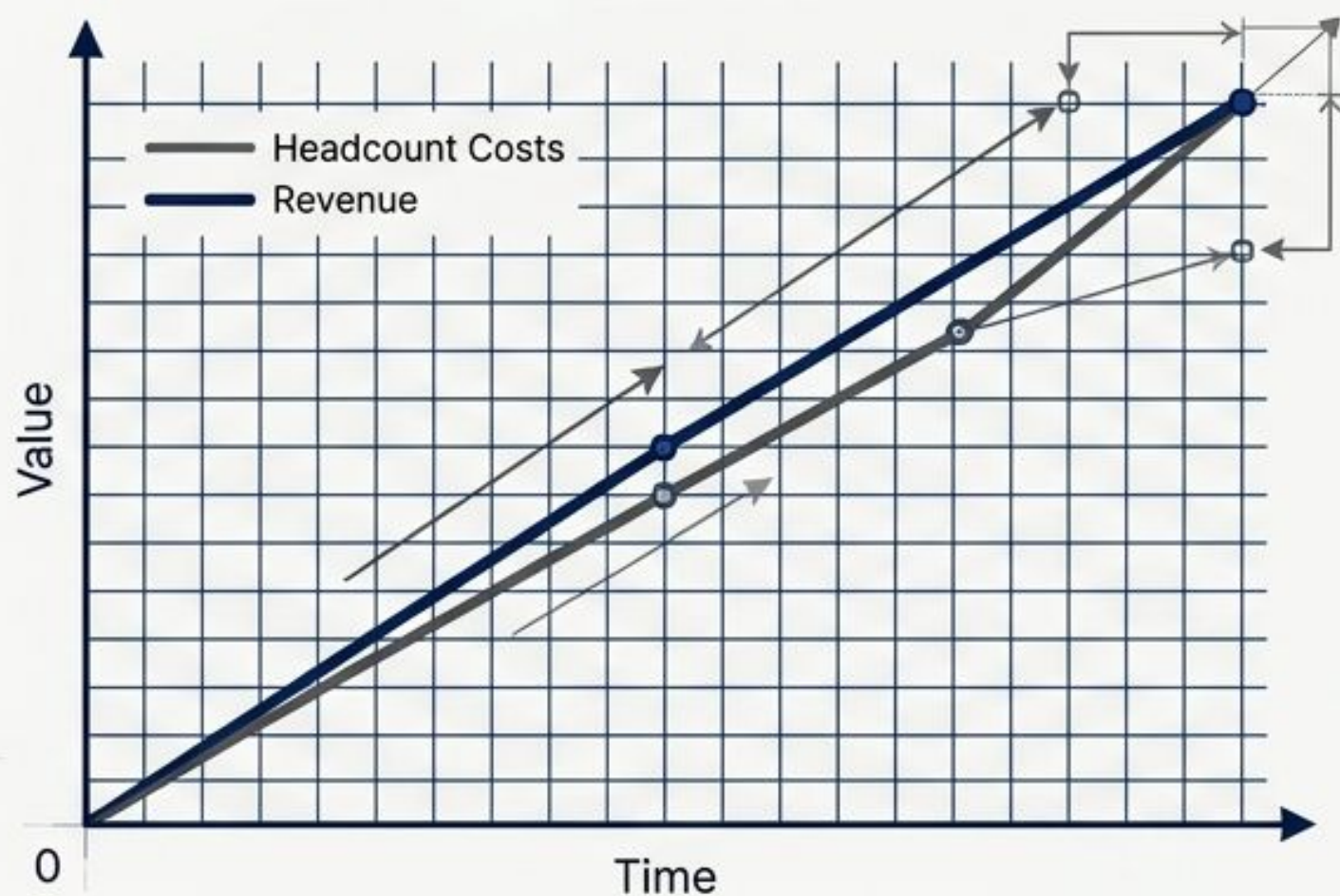

## AI-Driven Growth

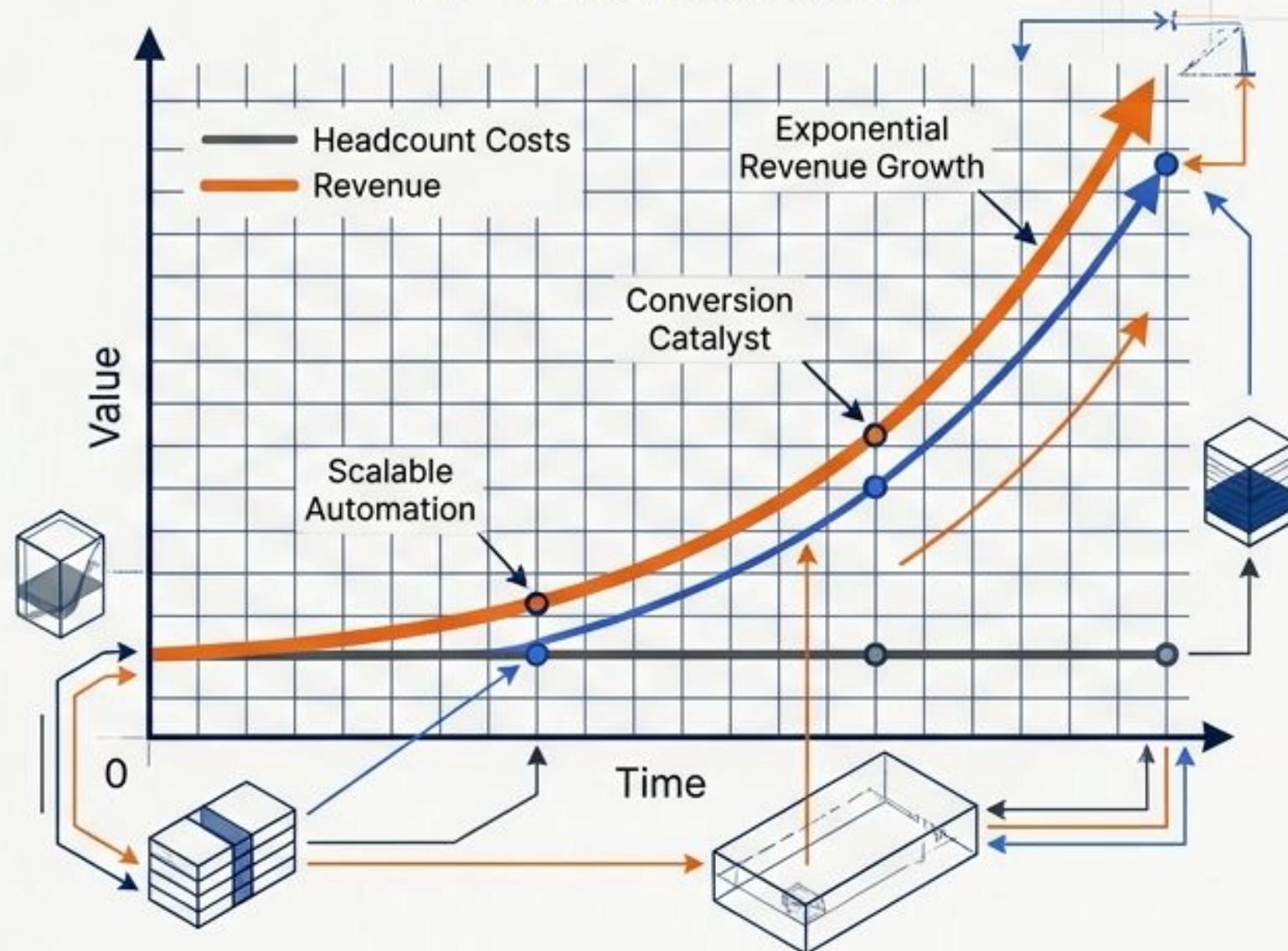

**AiBuilder.services**

# THE AI GROWTH ENGINE FOR SERVICE BUSINESSES

Scale your revenue, not your headcount.

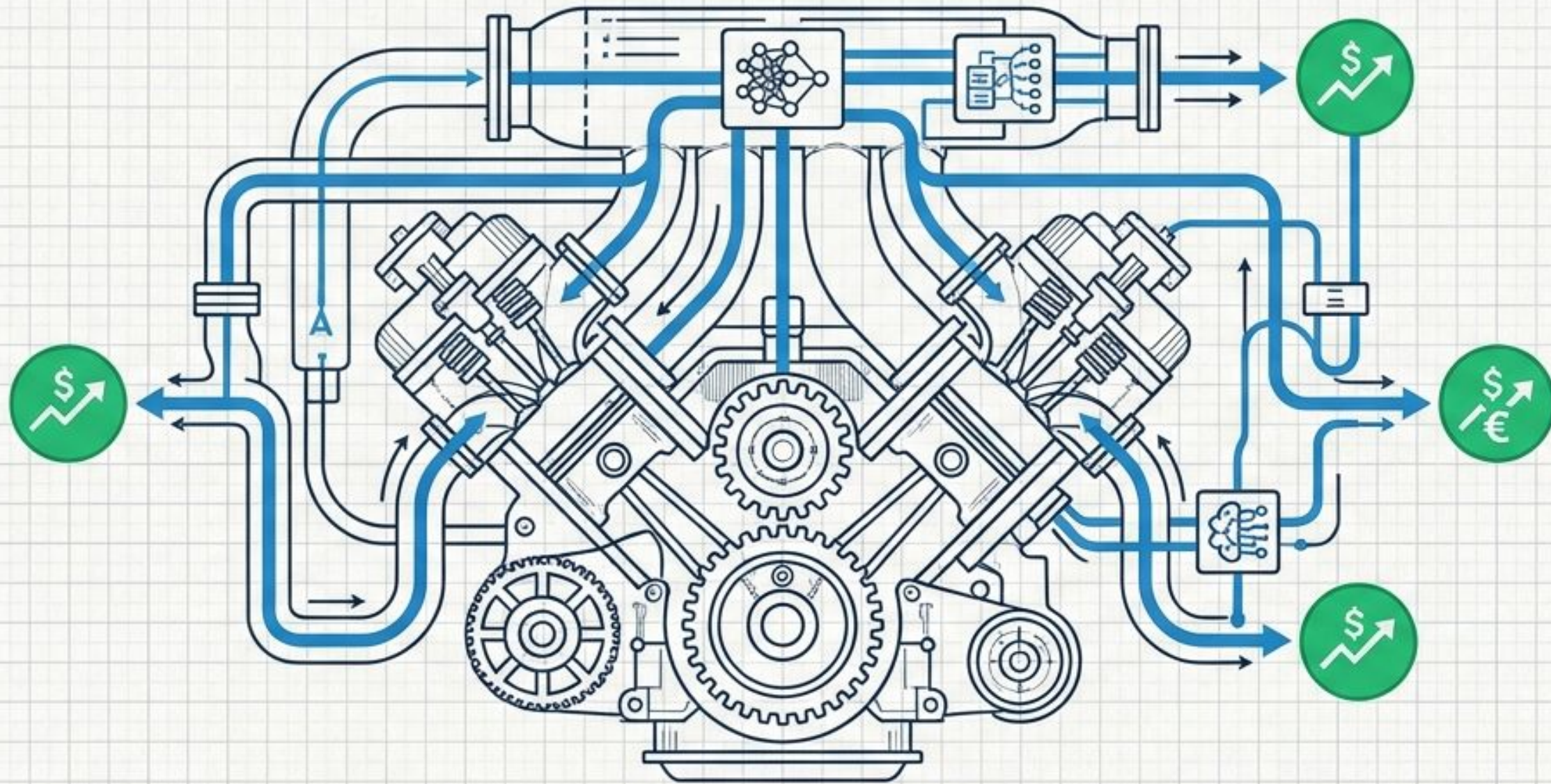

Trusted by 2,000+ service brands raising the bar.

# Breaking the traditional service growth trap

To grow your business, you add headcount. But scattered tools, manual follow-ups, and 24/7 demand mean overhead quickly eats your margins. Hatch decouples growth from headcount.

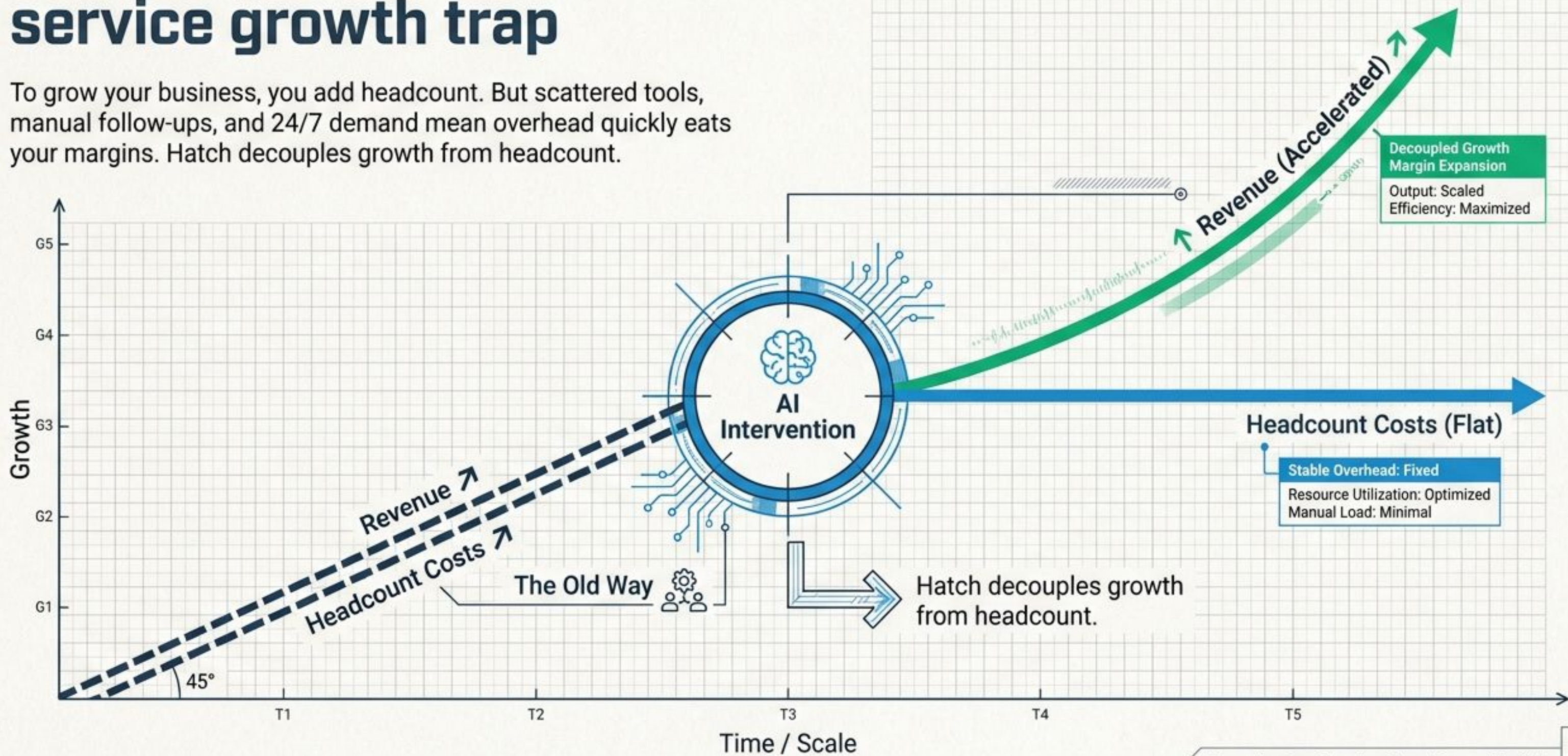

# The shift to the AI CSR Era

Scaling customer communication requires more than scripts. It requires a fundamental upgrade to your operational infrastructure.

## Traditional Service Operation

## The Hatch-Empowered Operation



**Availability**

Business Hours Only



**24/7 Intelligent Coverage**



**Response Time**

Hours  
(or ignored)



**< 1 Minute Instantly**



**Scalability**

Requires  
Constant Hiring



**Infrastructure-Driven  
Growth**



**Systems**

Scattered  
Tools & Silos

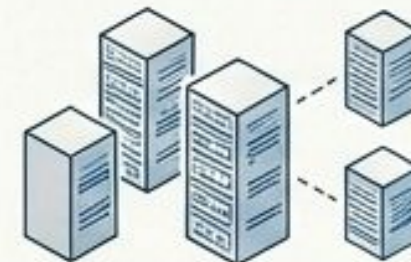

**Unified Human +  
AI Workspace**



# A unified, multi-layered revenue engine

Hatch is purpose-built for the workflows of home services and improvement operations, operating across four integrated layers.

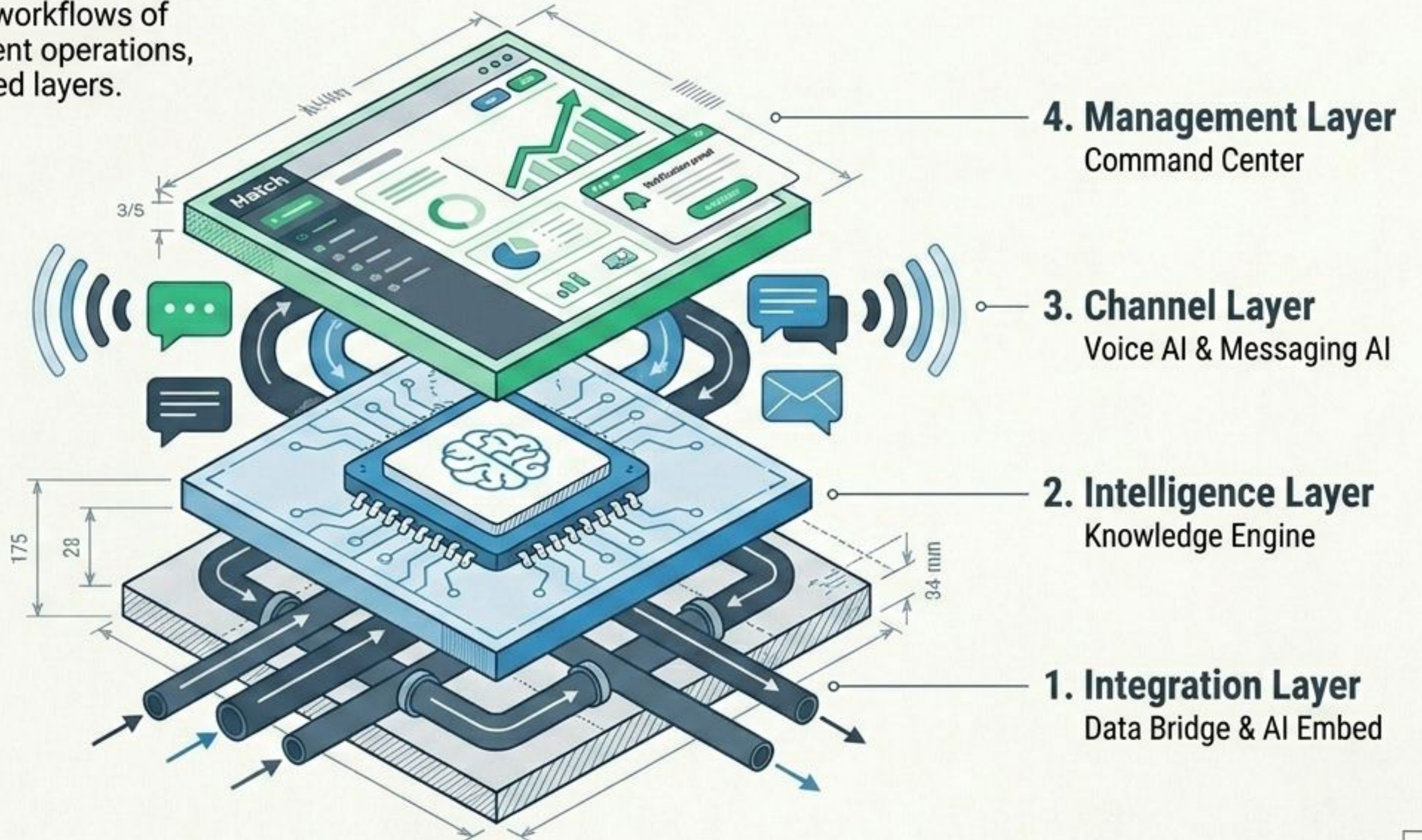

# 24/7 Voice AI that filters, qualifies, and books

Eliminate abandoned calls and off-hours missed opportunities. Hatch Voice AI delivers natural, low-latency interactions with warm transfers and complete transcripts.

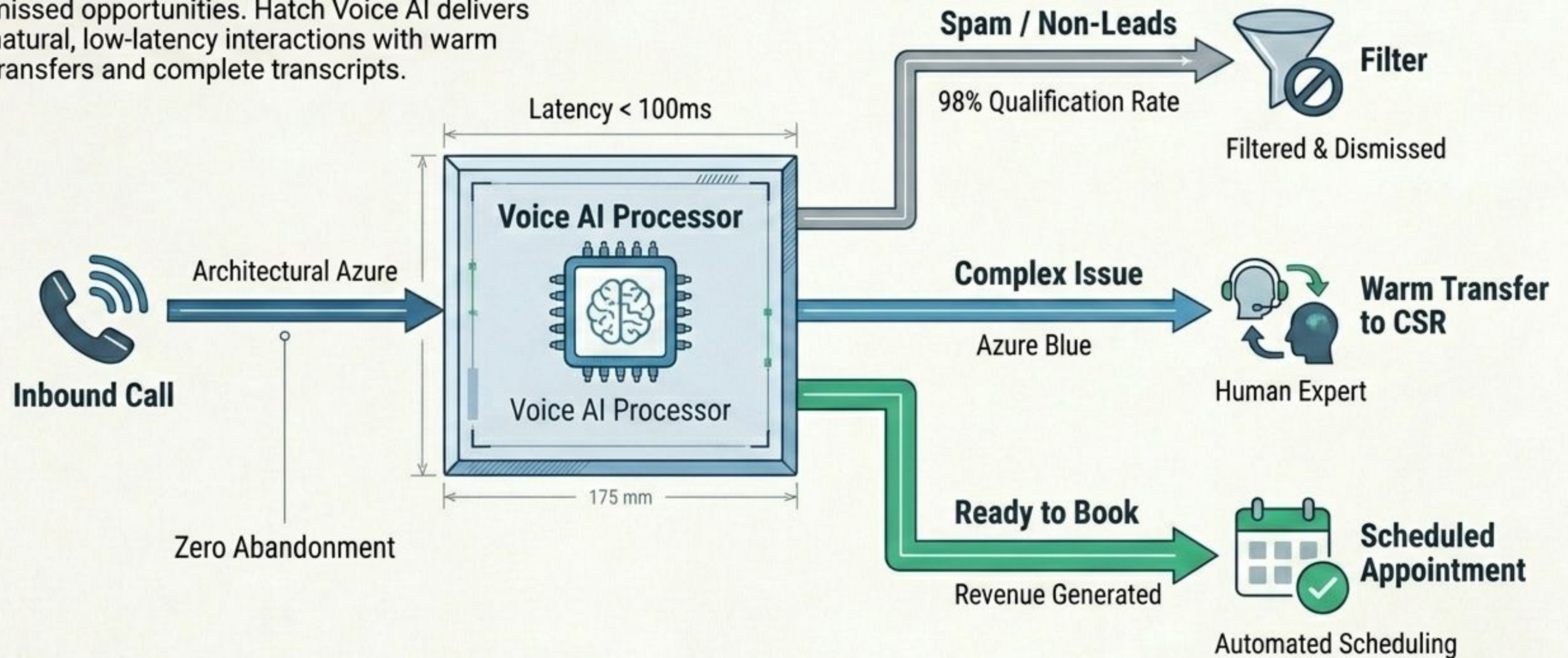

# Always-on messaging and automated journey building

AI doesn't just reply—it manages full conversations and orchestrates multi-channel journeys to nurture leads, re-engage customers, and drive conversion at every stage.

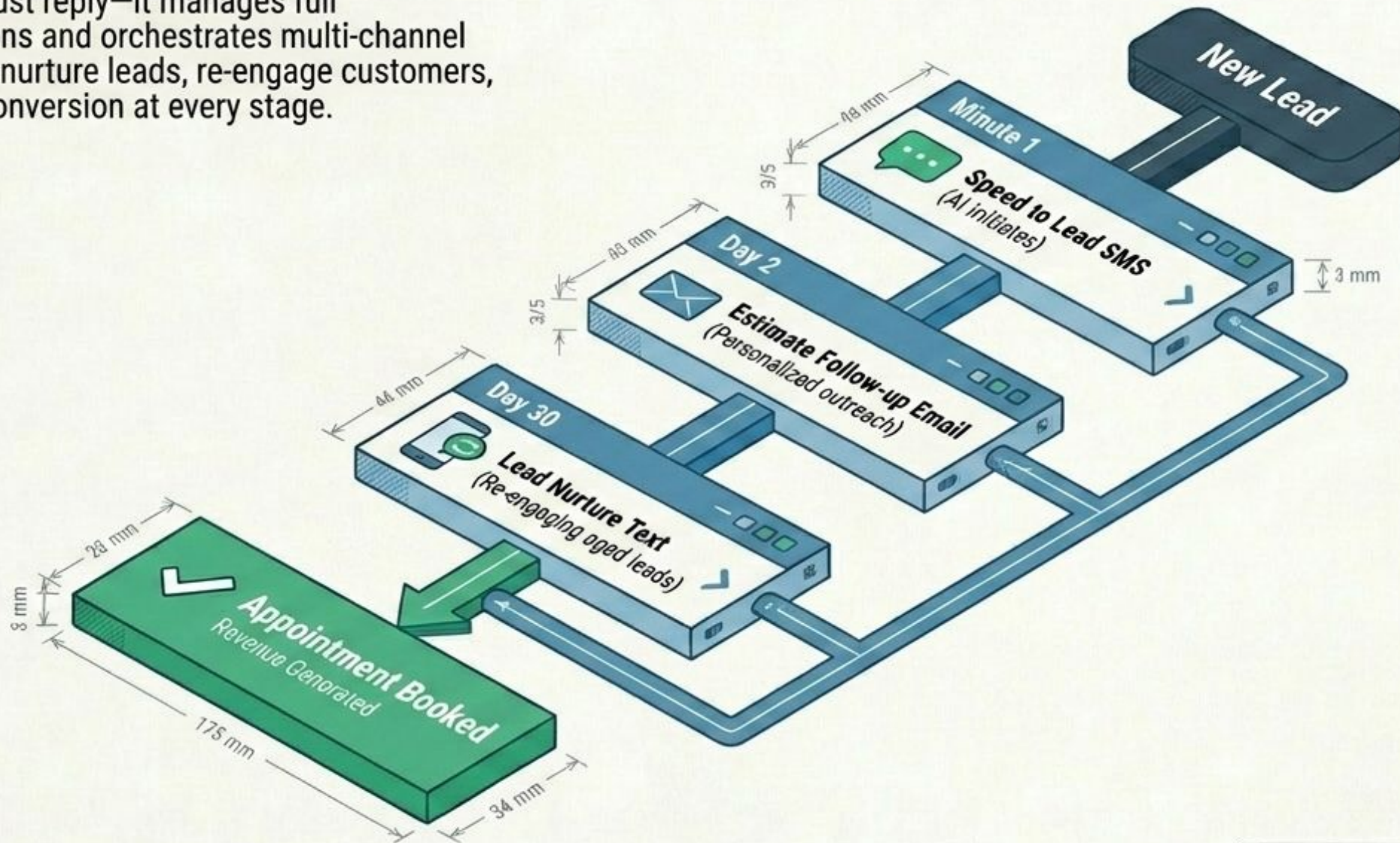

# Plugging the leaks in your revenue lifecycle

You don't always need new leads.  
You need to convert the ones falling through the cracks.

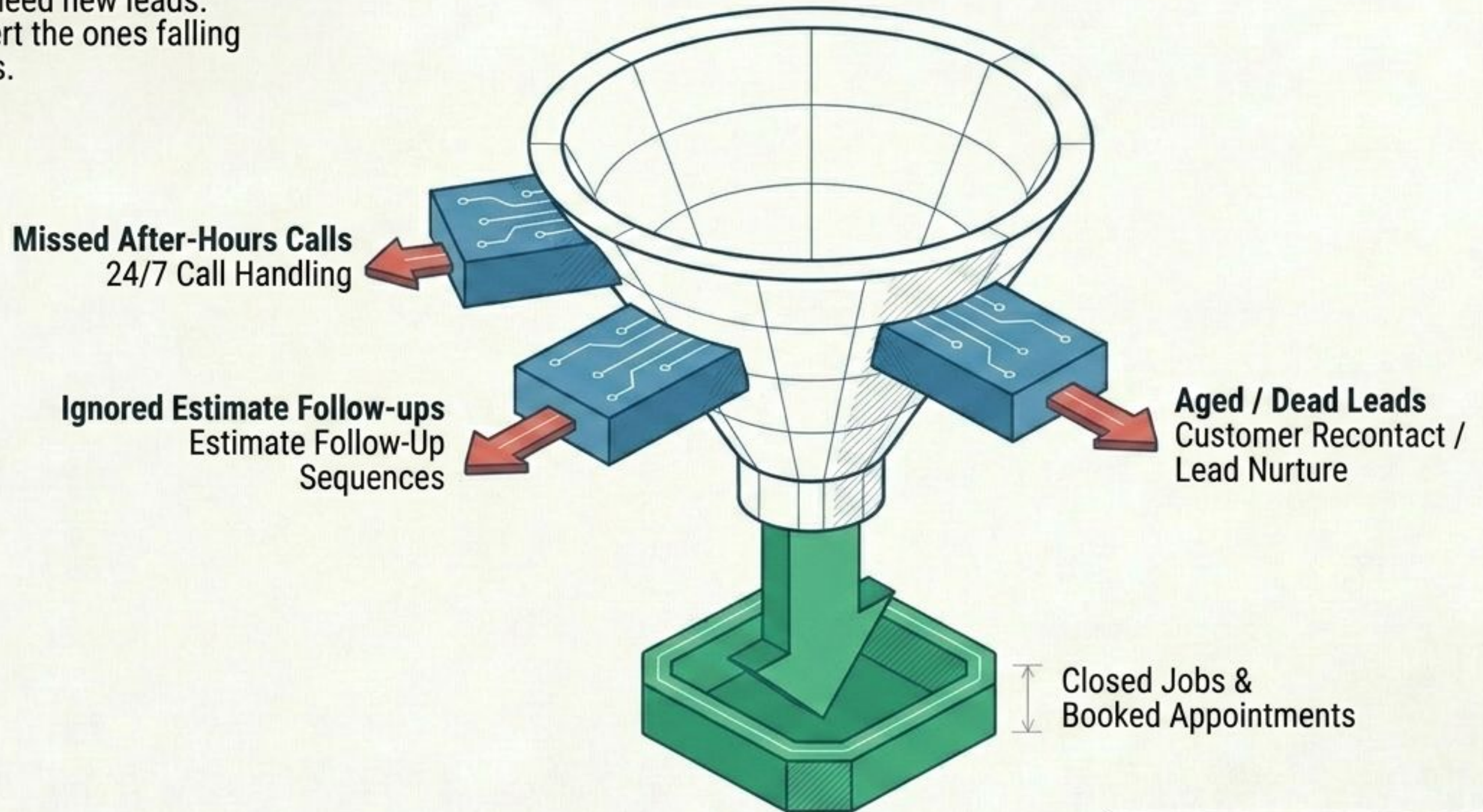

# Total operational control and precise AI training

Fine-tune every detail to stay on-brand and compliant. Review, conduct, and hand off conversations in a single unified workspace.

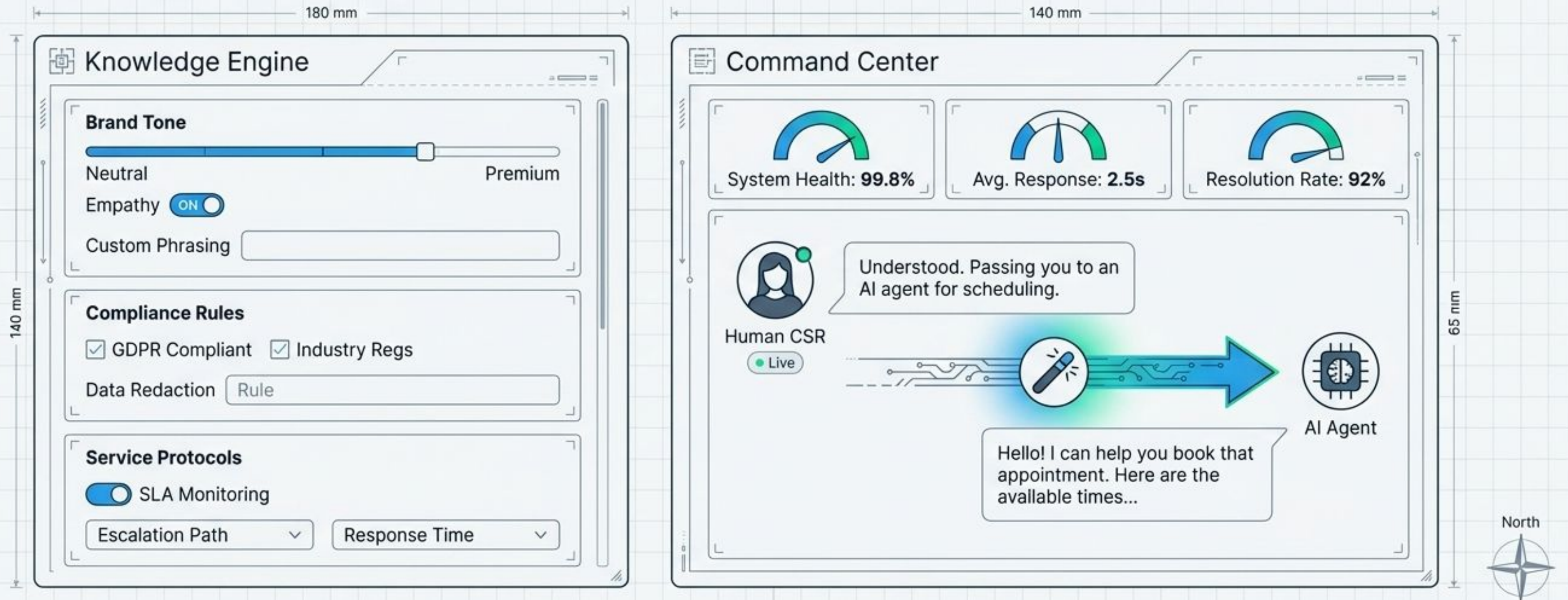

# Embedded natively into your existing ecosystem

Hatch integrates with your CRM, lead sources, marketing tools, and scheduling systems so your team and AI operate in one cohesive layer.

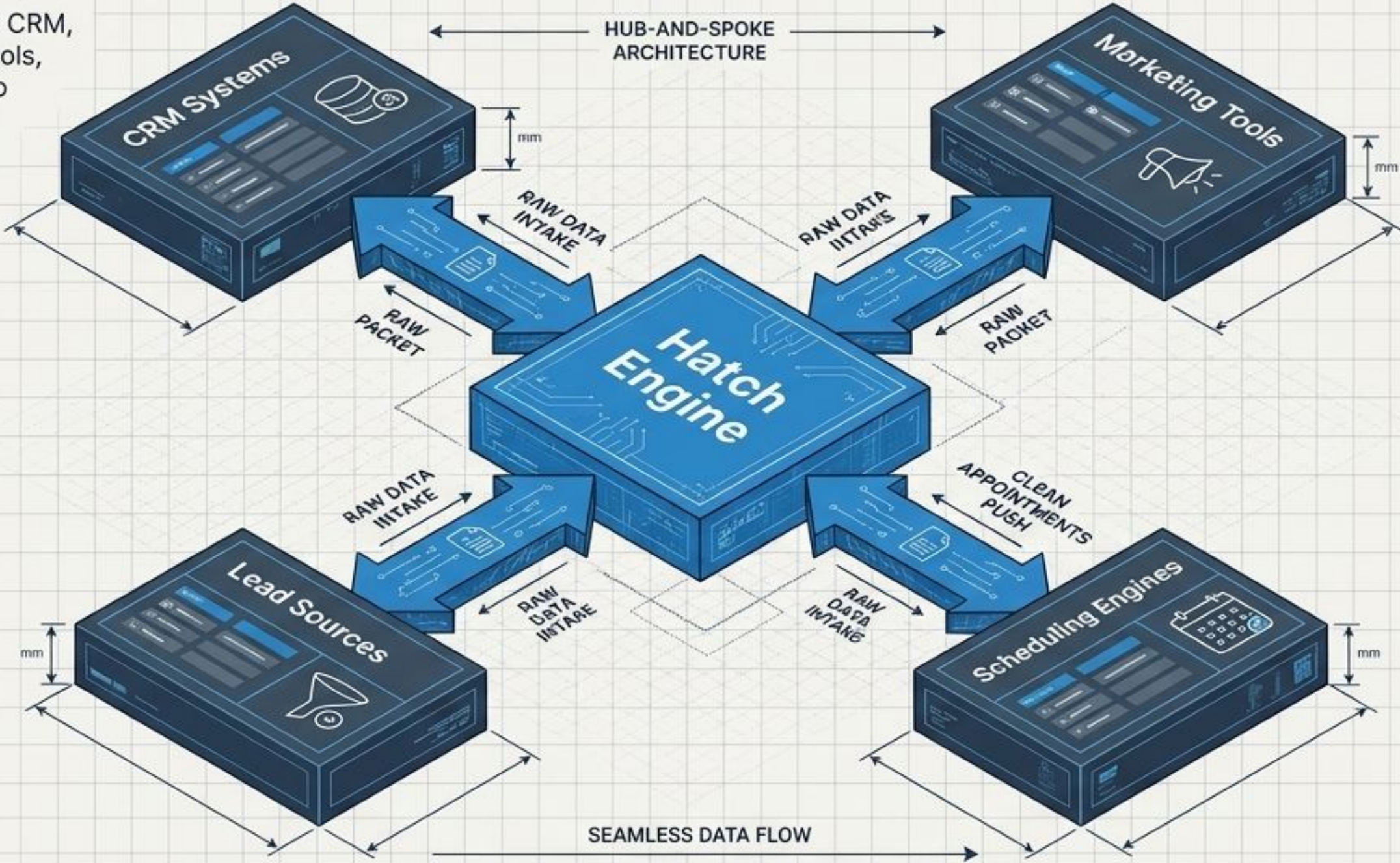

# Hands-off AI with hands-on control

Great service brands pair AI's speed with human judgment. Hatch creates an impenetrable net around your team—filtering the noise and booking the easy wins, so your CSRs only focus on high-value closing.

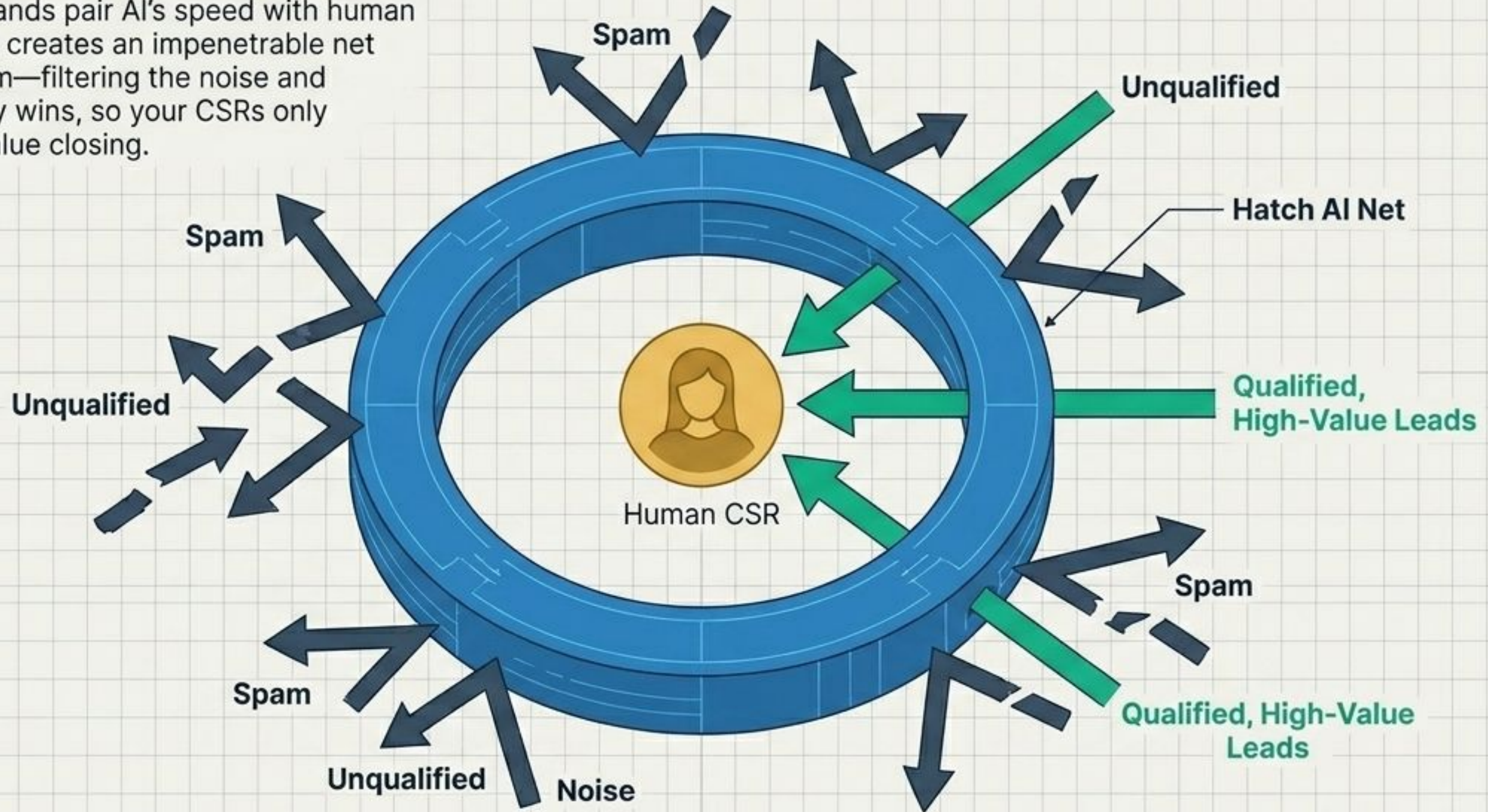

# The real-world impact of the AI revenue engine

How top service brands are shifting to faster, smarter, revenue-driving conversations.



# Lead the next decade of service operations

The strongest home service brands combine operational excellence with flawless customer experience. Embed AI into your processes the way you work, and turn communication into your ultimate competitive advantage.

[Get a Demo](#)

Rated 4.3 | Trusted by 2,000+ brands.

North



# The AI Infrastructure Paradigm

	Traditional Model	Hatch AI Infrastructure
Availability	✗ Business hours only	✓ 24/7/365 Omni-channel engagement
Speed to Lead	✗ Minutes, hours, or missed completely	✓ <b>Instant response</b> (< 1 minute)
Scaling Cost	✗ Linear (Hire more CSRs to handle volume)	✓ <b>Scalable Infrastructure</b> (Flat cost for infinite scale)
Tooling	✗ Scattered (Phone, SMS, Email silos)	✓ <b>Unified Workspace</b> (Command Center)

# One Unified Workspace

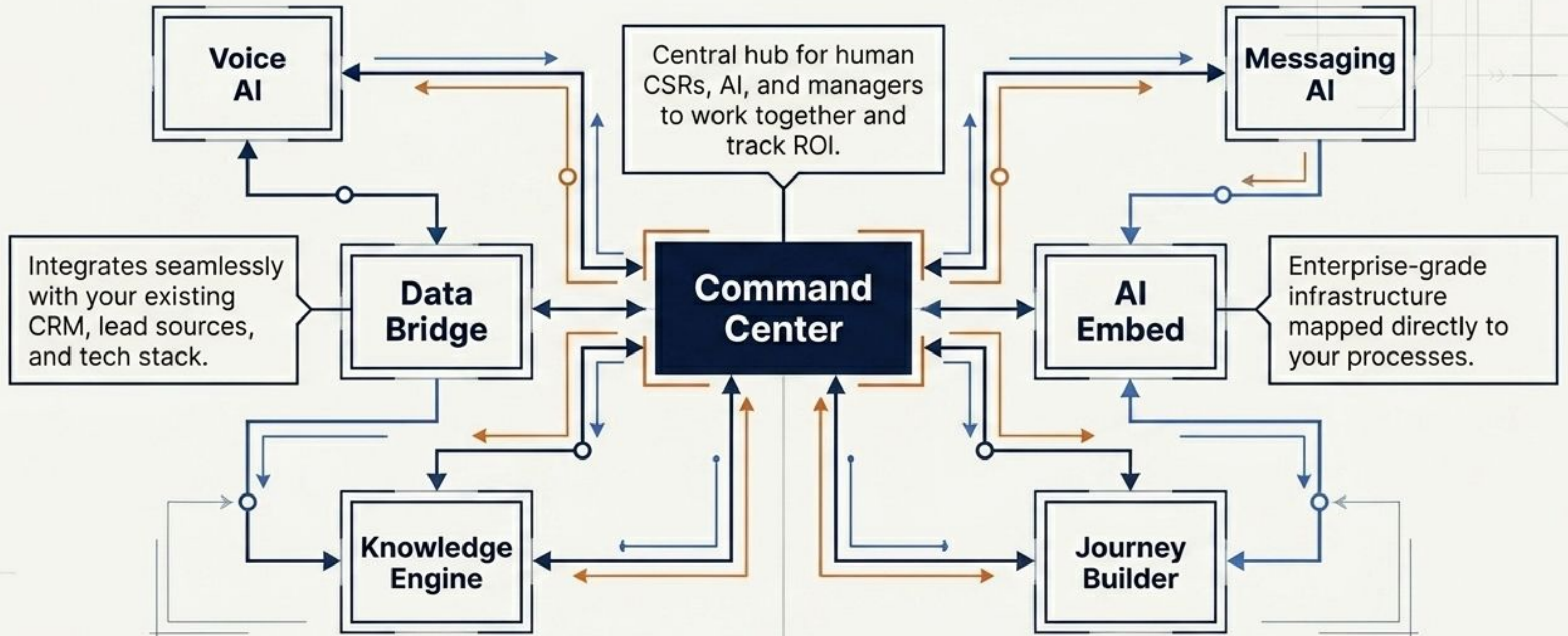

**AiBuilder.services**

# 24/7 Always-On Engagement

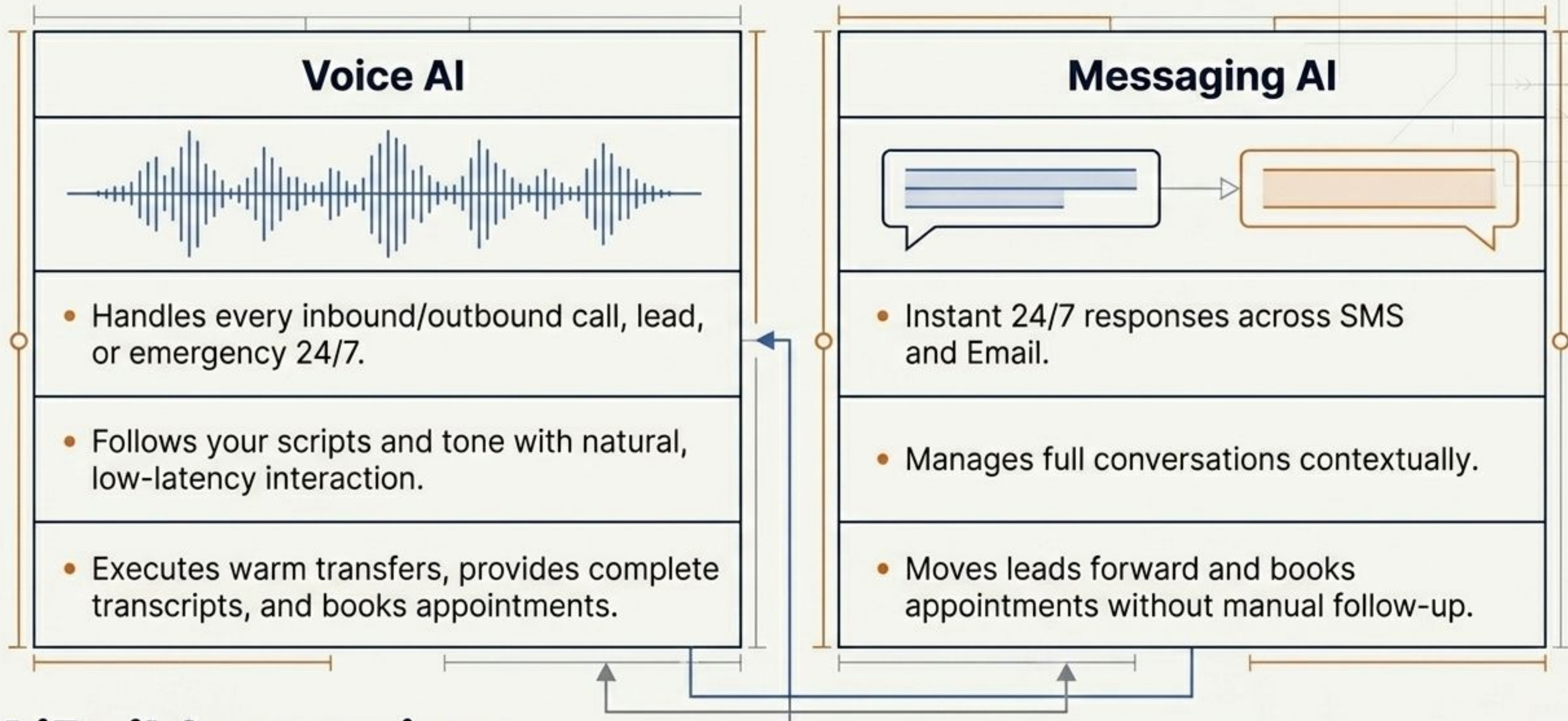

**AiBuilder.services**

# Hands-Off AI With Hands-On Control

## Knowledge Engine

Fine-tune every detail. Train your AI to stay 100% on-brand, compliant, and focused on operational outcomes, not just conversational responses.

## Journey Builder

Architect brand-defining customer journeys. Coordinate automated sequences across SMS, email, and voice to drive conversion at every specific stage of your funnel.

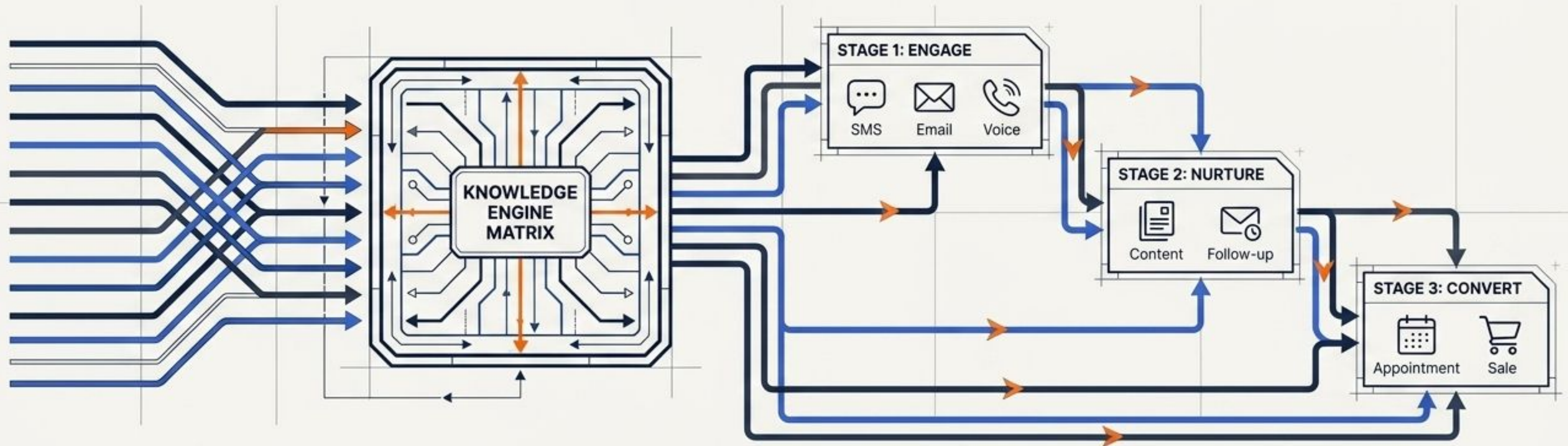

**AiBuilder.services**

# Proactive Engagement at Every Stage

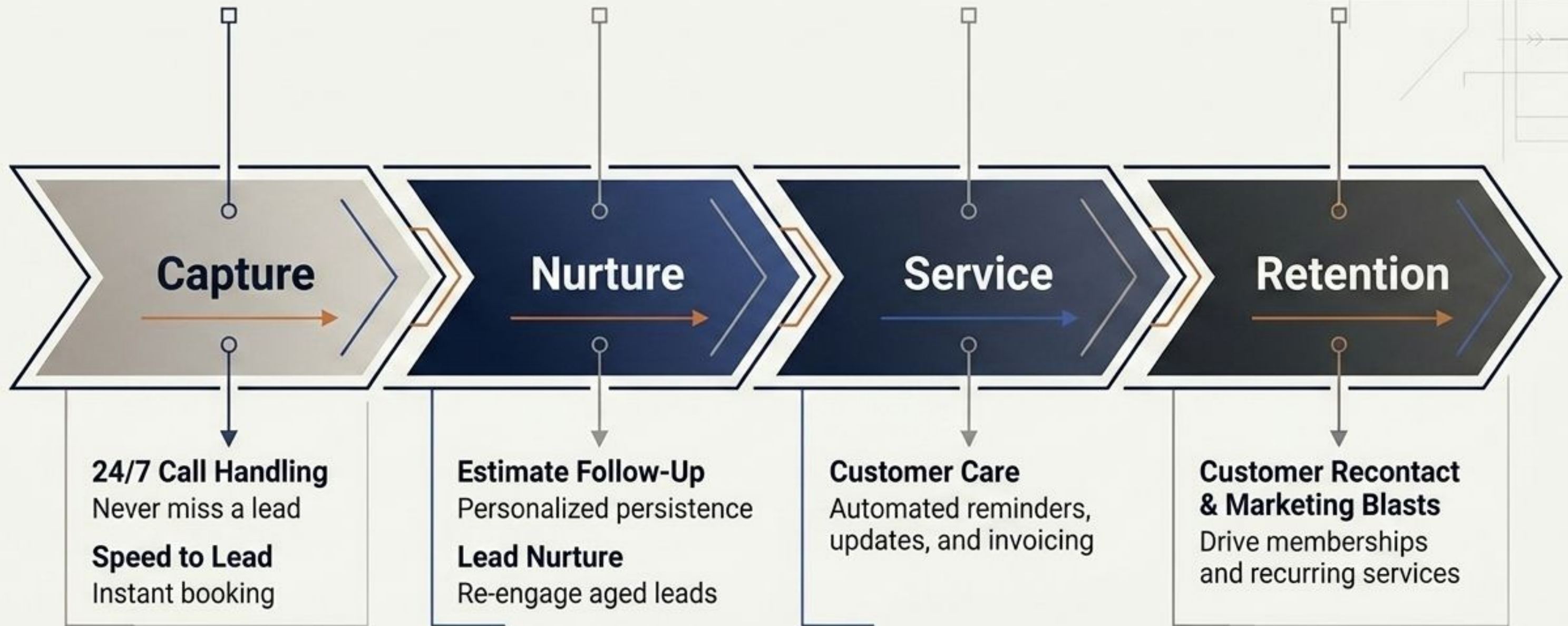

**AiBuilder.services**

# Proven Impact Across 2,000+ Brands

**\$70M**

Client revenue influenced in the last 12 months. (Free Agency)

**81%**

Of bookable leads successfully handled and booked by AI. (High Ground)

**3X**

Increase in conversion rate on after-hours and overflow calls. (Peaden)

**84%**

Total reduction in missed calls. (Trevor Calero)

**AiBuilder.services**

# “We grew over 30% last year and we didn’t add any people to do all that work.”

Jason Dowdy, COO, Pella

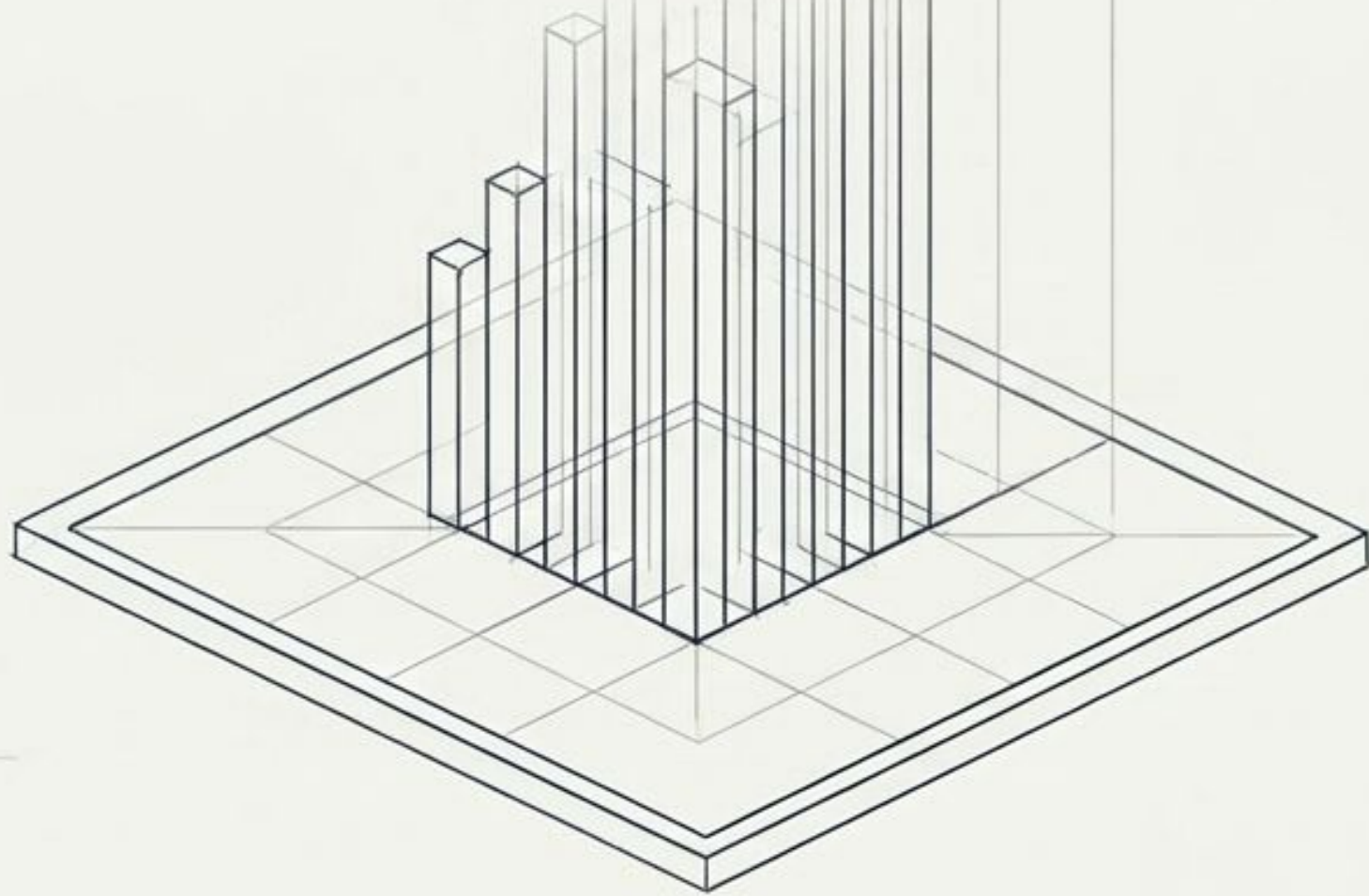

**30%** Revenue Growth  
Without Staff

AI handles the top-of-funnel heavy lifting and endless follow-ups, allowing human CSRs to focus exclusively on high-value, ready-to-buy leads.

**74%** Response Rate  
on Rehash

AI handles the top-of-funnel heavy lifting and endless follow-ups, allowing human CSRs to focus exclusively on high-value, ready-to-buy leads.

**AiBuilder.services**

# Monetizing the Leads You Already Have

“You don’t have to go find new leads. Just take care of the ones who already want to do business with you.”

Matt Tyner, CMO, Bone Dry Roofing

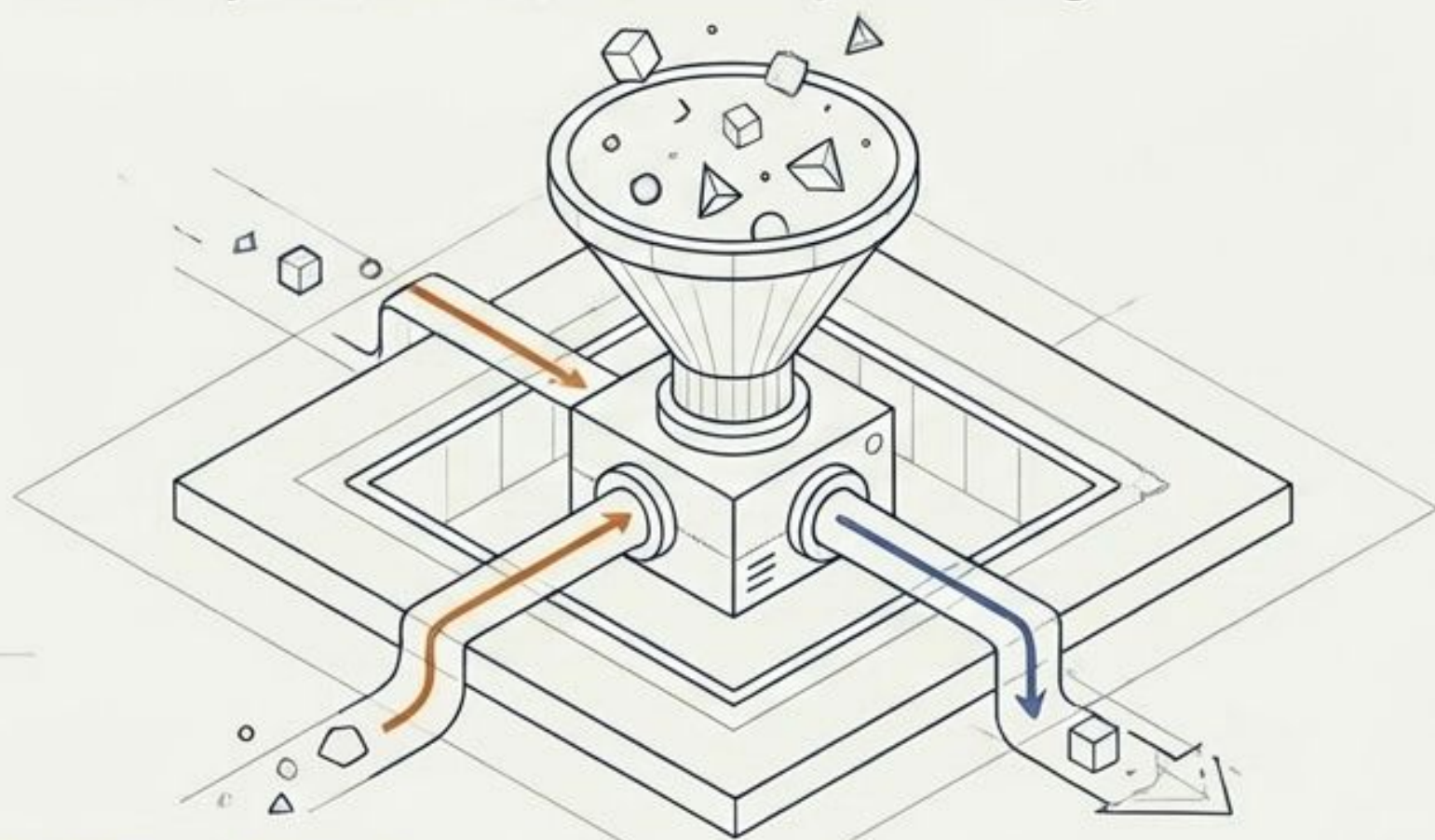

**AiBuilder.services**

**\$7M+** Closed From  
**Rehash Follow-up**

Persistent, personalized AI follow-up automatically turns aged leads, outstanding estimates, and no-shows into booked revenue without human effort.

**2.5x** Higher  
**Booking Rate**

Persistent, personalized AI follow-up automatically turns aged leads, outstanding estimates, and no-shows into booked revenue without human effort.

# Built for Your Tech Stack

Consolidation is Key

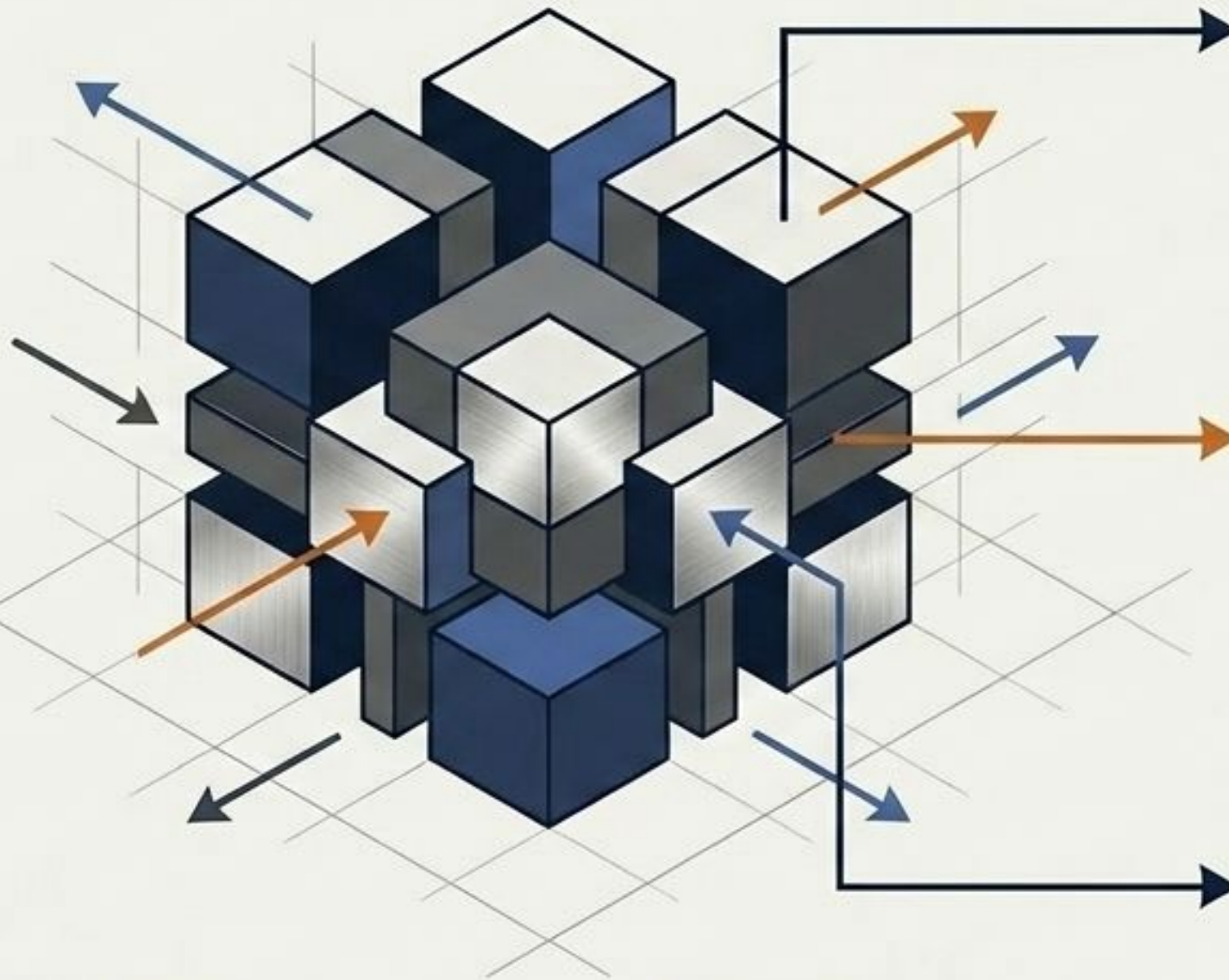

- **Integrates directly with your existing** CRM, lead sources, marketing tools, and scheduling systems.

- **Built for Every Scale**

Engineered for SMBs, Mid-Market, PE-backed roll-ups, and Multi-Location Enterprises.

- **Standardize at Scale**

Unify complex communications across branches into one cohesive, trackable layer.

**AiBuilder.services**

# Lead the Next Decade of AI-Driven Service Operations

Great service brands combine operational excellence with elite customer experience. AI enhances that—it doesn't replace it. Stop scaling costs. Start scaling revenue.

**Experience it yourself.  
Talk to Hatch Voice AI today.**

**AiBuilder.services**