

The AI Growth Engine for Service Businesses

Scale revenue,
not headcount.

AiBuilder.services

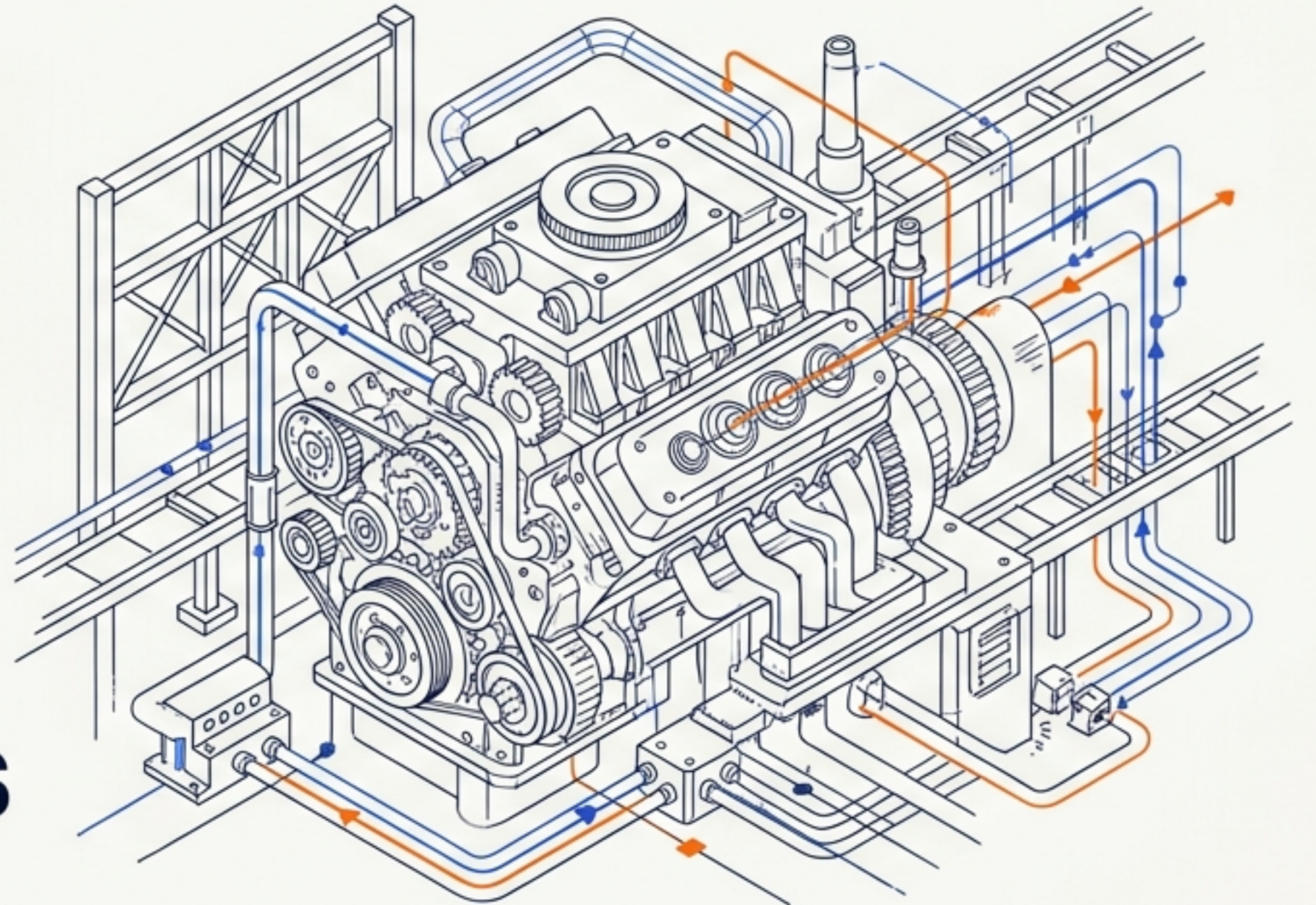

Turn Customer Communication Into a Revenue Engine

For service businesses, communication is everything. Consolidate scattered tools and manual follow-ups into a single AI layer. Ensure every conversation is a catalyst for satisfaction, conversion, and growth without adding overhead.

Traditional Growth

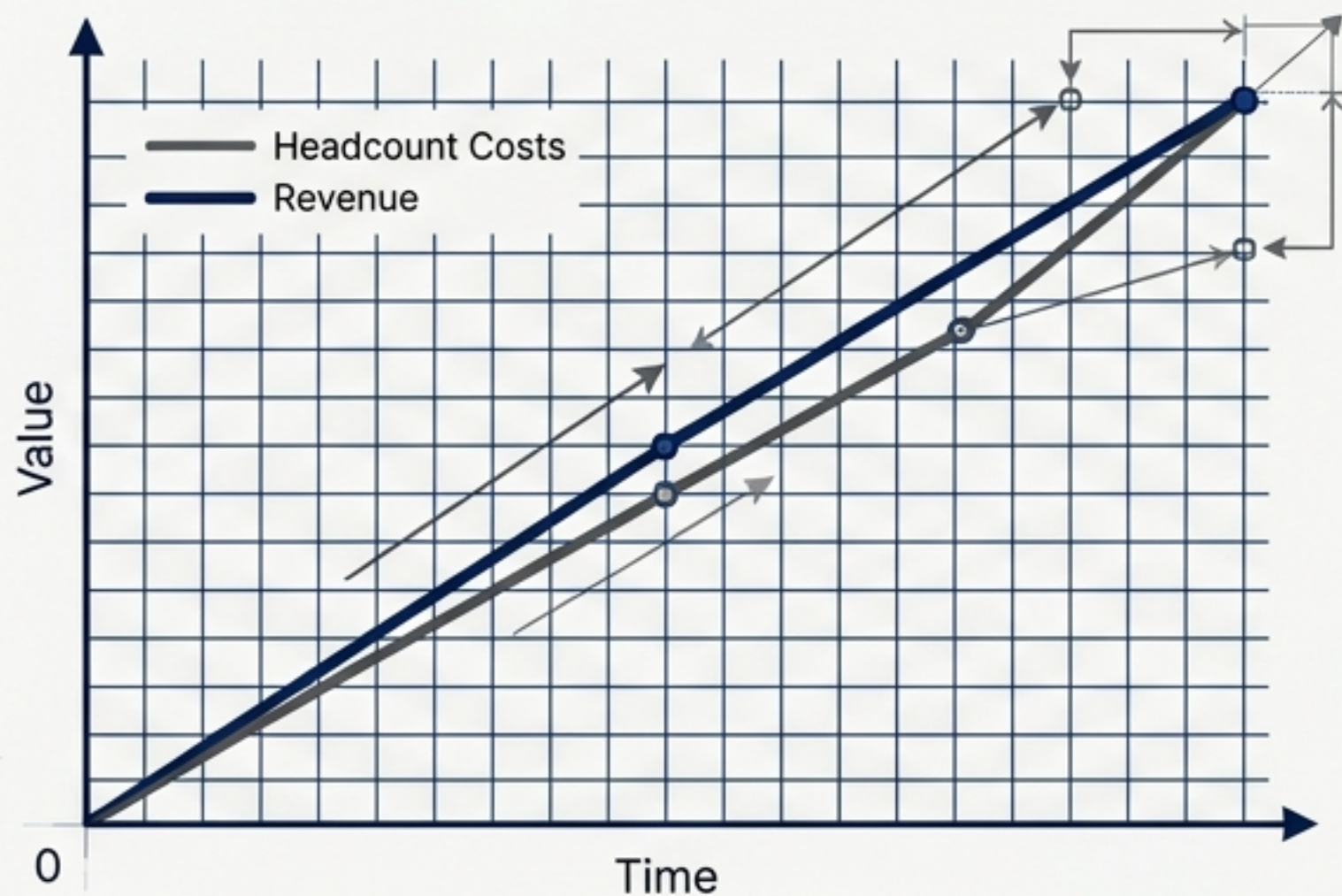

AI-Driven Growth

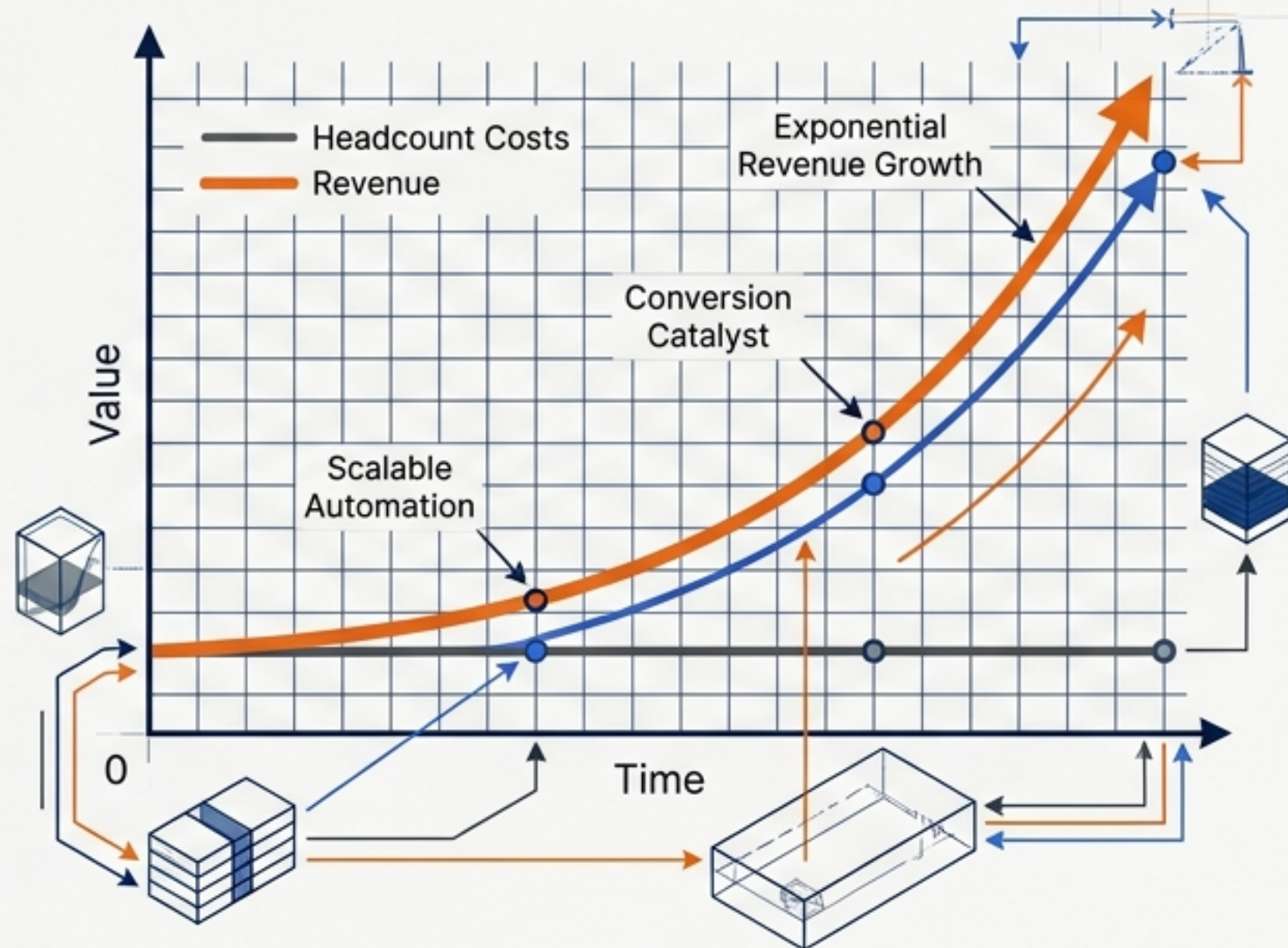

AiBuilder.services

The AI Infrastructure Paradigm

	Traditional Model	Hatch AI Infrastructure
Availability	✗ Business hours only	✓ 24/7/365 Omni-channel engagement
Speed to Lead	✗ Minutes, hours, or missed completely	✓ Instant response (< 1 minute)
Scaling Cost	✗ Linear (Hire more CSRs to handle volume)	✓ Scalable Infrastructure (Flat cost for infinite scale)
Tooling	✗ Scattered (Phone, SMS, Email silos)	✓ Unified Workspace (Command Center)

AiBuilder.services

One Unified Workspace

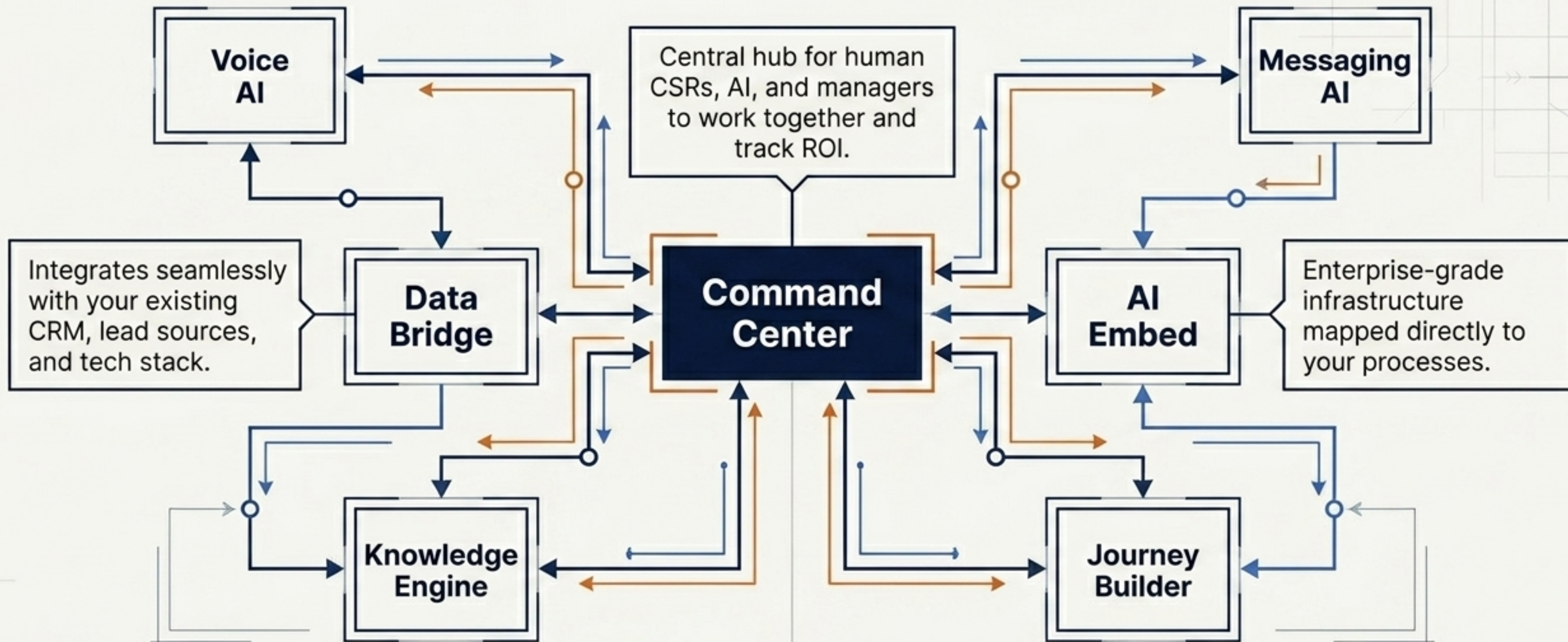

AiBuilder.services

24/7 Always-On Engagement

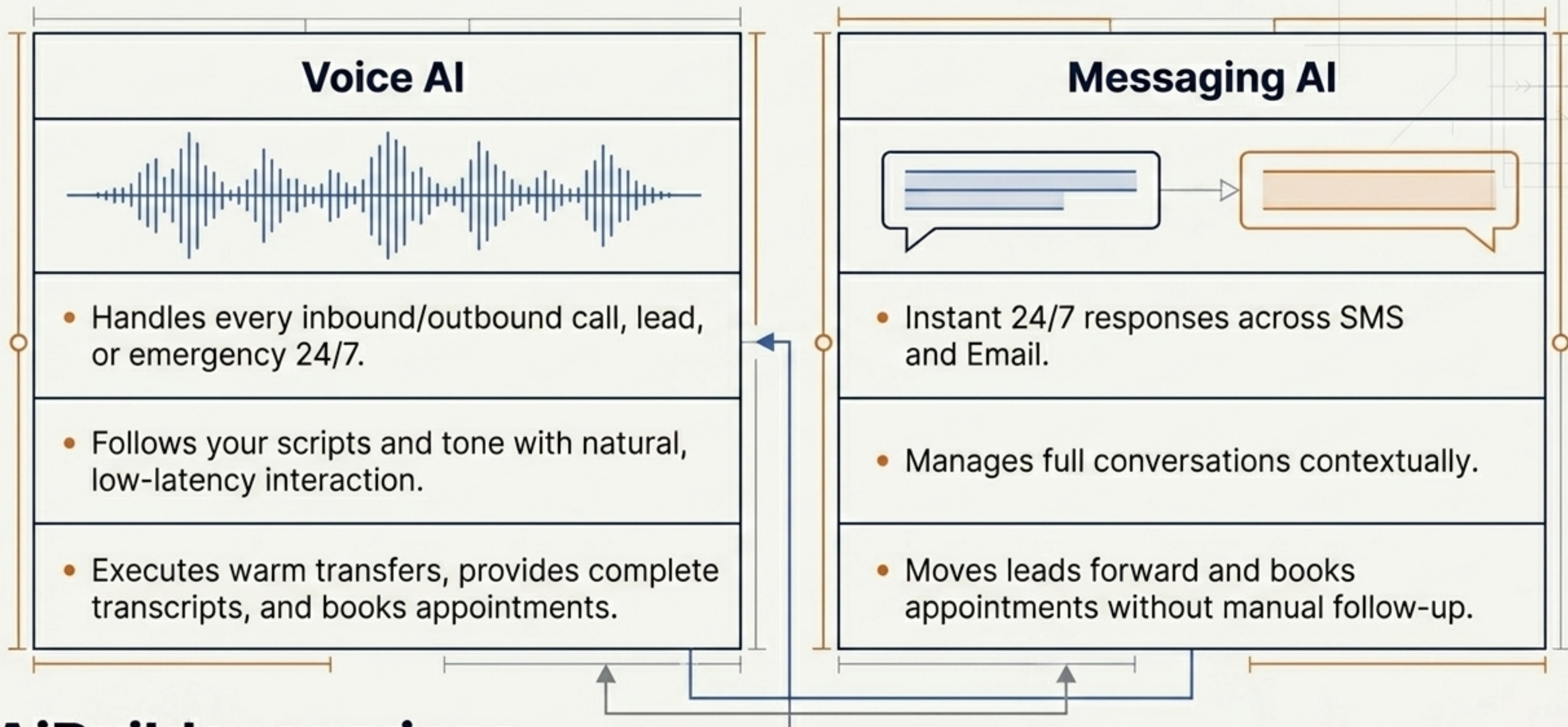

AiBuilder.services

Hands-Off AI With Hands-On Control

Knowledge Engine

Fine-tune every detail. Train your AI to stay 100% on-brand, compliant, and focused on operational outcomes, not just conversational responses.

Journey Builder

Architect brand-defining customer journeys. Coordinate automated sequences across SMS, email, and voice to drive conversion at every specific stage of your funnel.

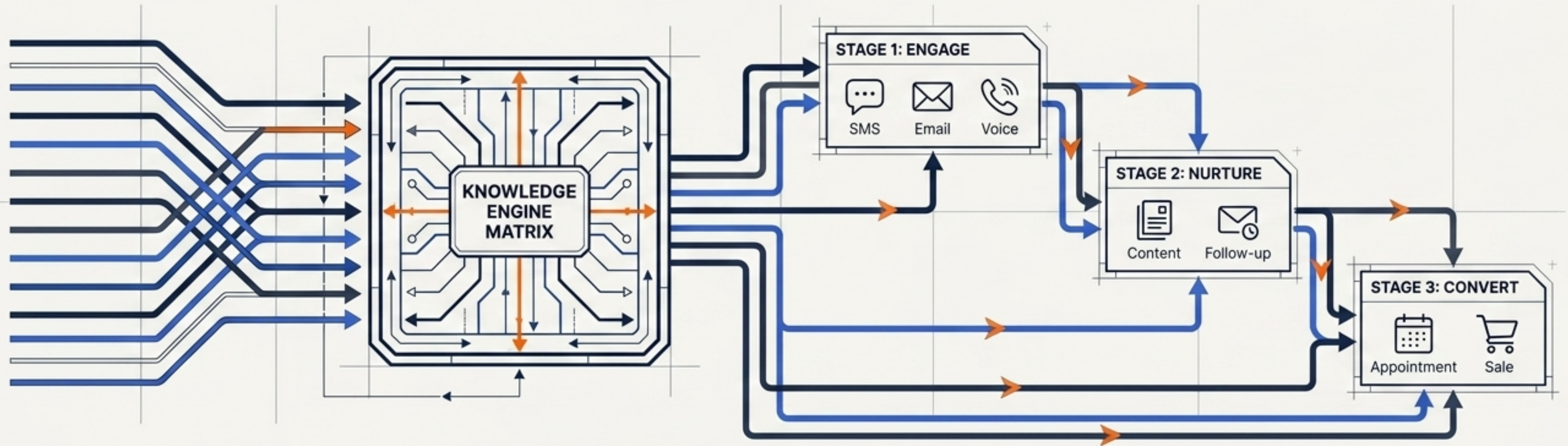

AiBuilder.services

Proactive Engagement at Every Stage

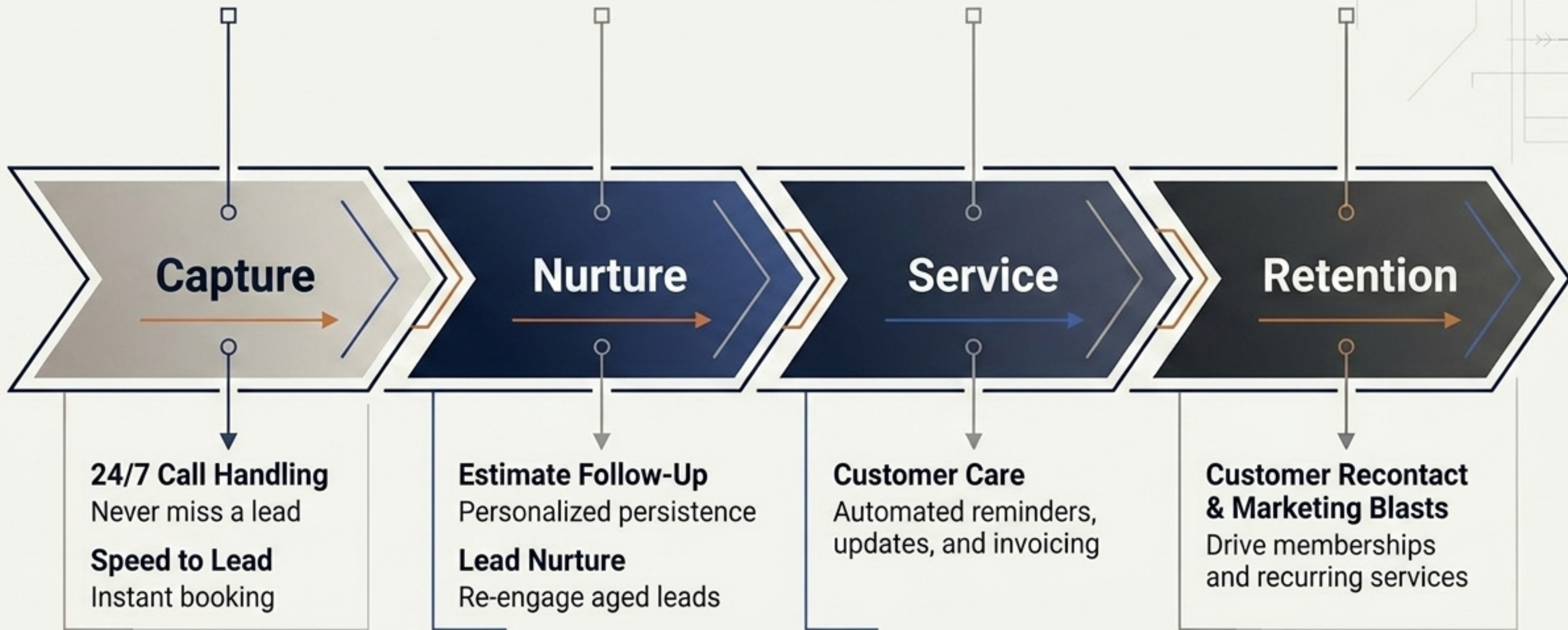

AiBuilder.services

Proven Impact Across 2,000+ Brands

\$70M

Client revenue influenced in the last 12 months. (Free Agency)

81%

Of bookable leads successfully handled and booked by AI. (High Ground)

3X

Increase in conversion rate on after-hours and overflow calls. (Peaden)

84%

Total reduction in missed calls. (Trevor Calero)

AiBuilder.services

“We grew over 30% last year and we didn’t add any people to do all that work.”

Jason Dowdy, COO, Pella

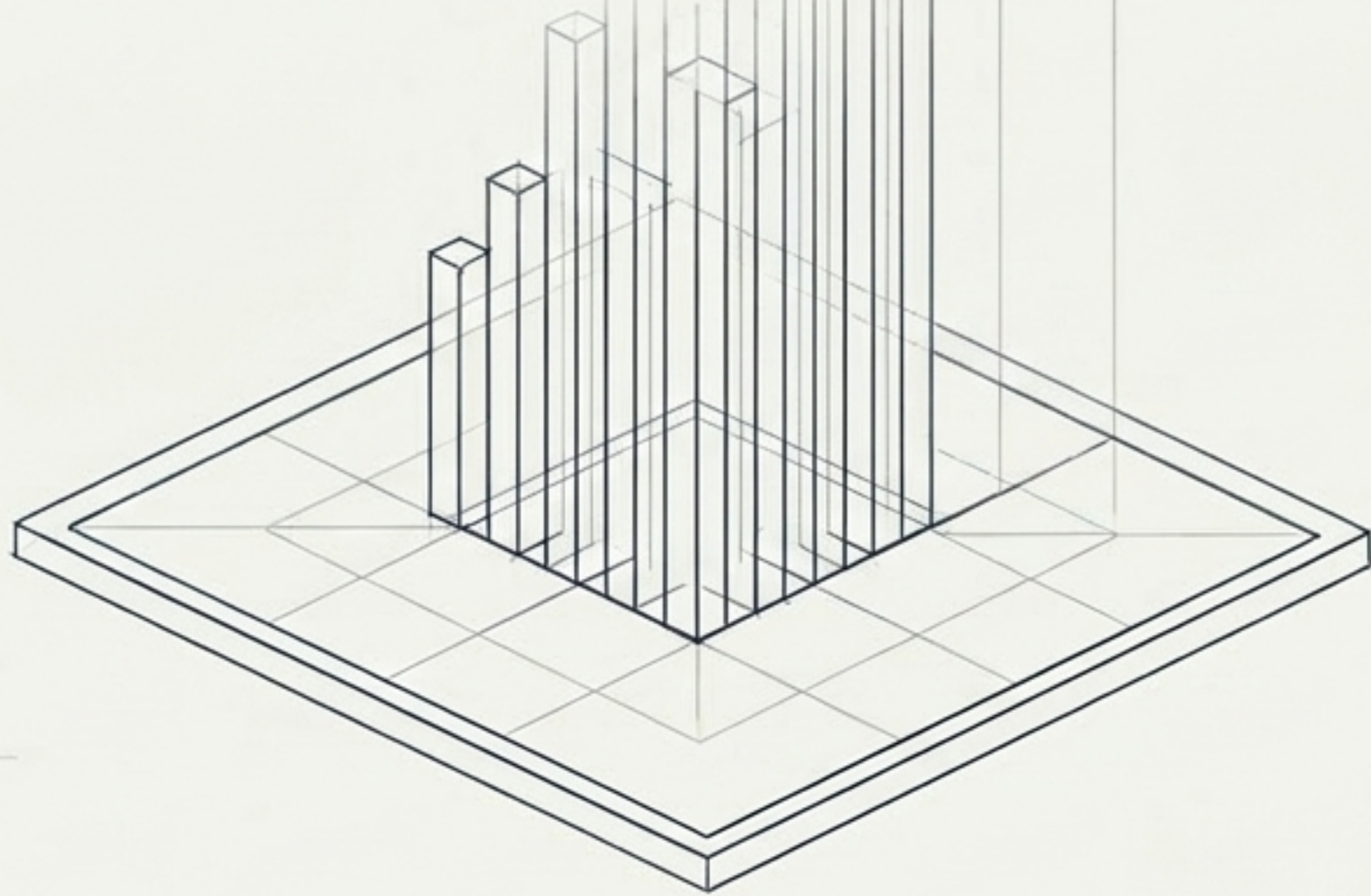

30% Revenue Growth
Without Staff

AI handles the top-of-funnel heavy lifting and endless follow-ups, allowing human CSRs to focus exclusively on high-value, ready-to-buy leads.

74% Response Rate
on Rehash

AI handles the top-of-funnel heavy lifting and endless follow-ups, allowing human CSRs to focus exclusively on high-value, ready-to-buy leads.

AiBuilder.services

Monetizing the Leads You Already Have

“You don’t have to go find new leads. Just take care of the ones who already want to do business with you.”

Matt Tyner, CMO, Bone Dry Roofing

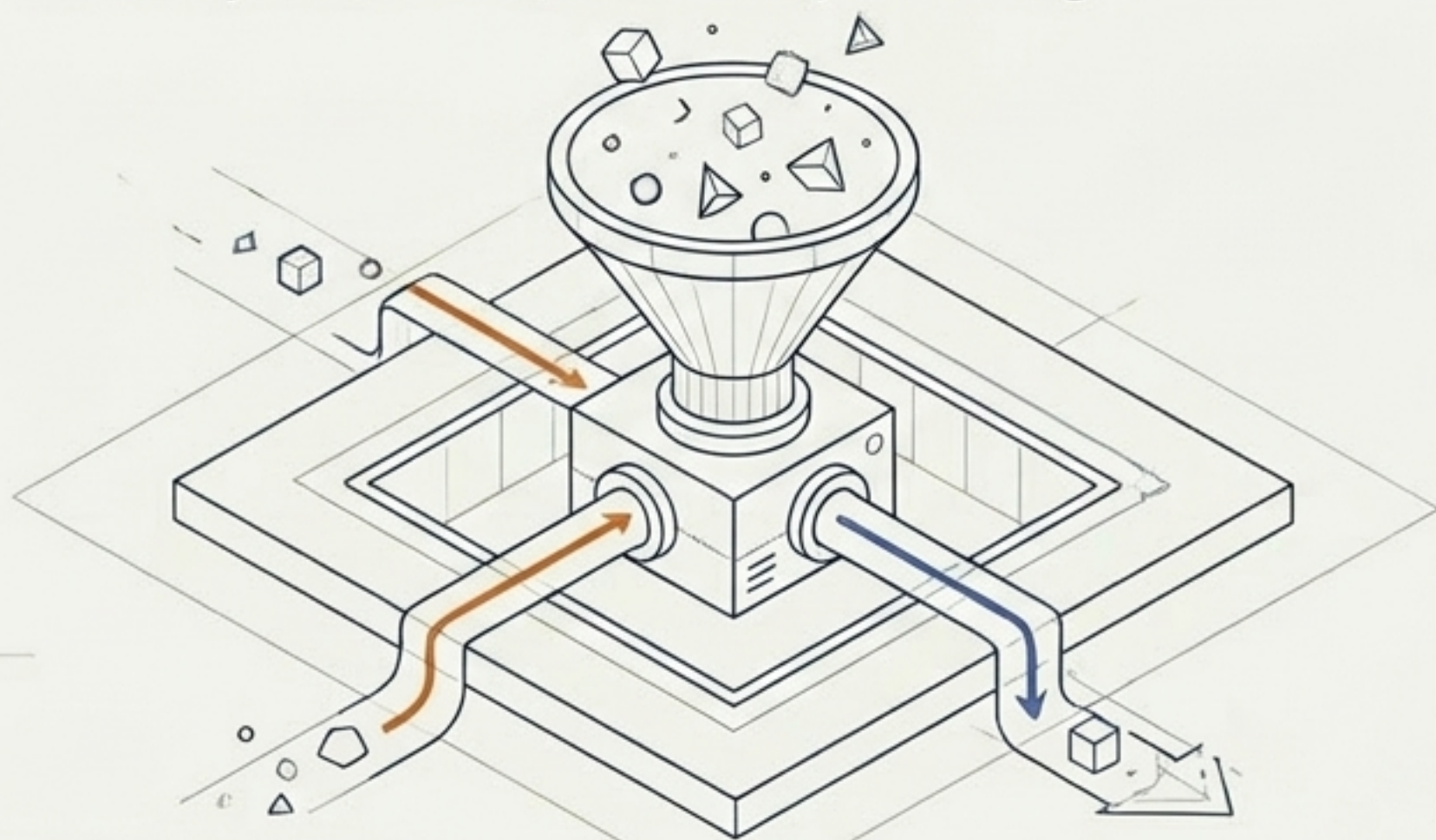

AiBuilder.services

\$7M+ Closed From
Rehash Follow-up

Persistent, personalized AI follow-up automatically turns aged leads, outstanding estimates, and no-shows into booked revenue without human effort.

2.5x Higher
Booking Rate

Persistent, personalized AI follow-up automatically turns aged leads, outstanding estimates, and no-shows into booked revenue without human effort.

Built for Your Tech Stack

Consolidation is Key

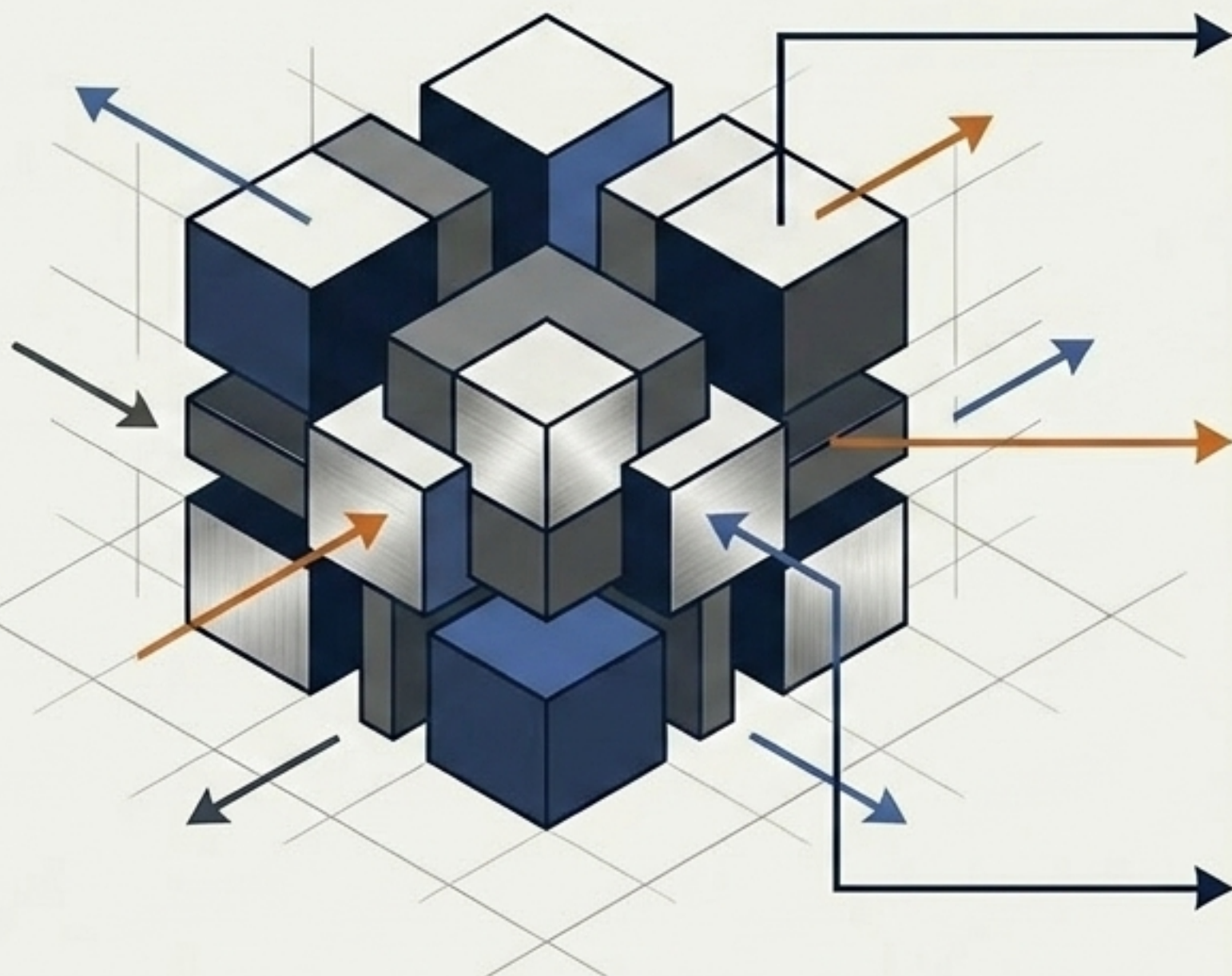

- **Integrates directly with your existing** CRM, lead sources, marketing tools, and scheduling systems.

- **Built for Every Scale**

Engineered for SMBs, Mid-Market, PE-backed roll-ups, and Multi-Location Enterprises.

- **Standardize at Scale**

Unify complex communications across branches into one cohesive, trackable layer.

AiBuilder.services

Lead the Next Decade of AI-Driven Service Operations

Great service brands combine operational excellence with elite customer experience. AI enhances that—it doesn't replace it. Stop scaling costs. Start scaling revenue.

**Experience it yourself.
Talk to Hatch Voice AI today.**

AiBuilder.services